

THE  
VENTILATOR  
BOOK

---

Second Edition

William Owens, MD

THE  
VENTILATOR  
BOOK

---

Second Edition

William Owens, MD



THE  
VENTILATOR  
BOOK

---

Second Edition

William Owens, MD



First Draught Press

# **The Ventilator Book**

**William Owens, MD**

**First Draught Press  
MMXVIII**

*Medicine is an ever-changing discipline and the subject matter of this book is no exception. While the author has done his best to ensure that this book reflects contemporary evidence-based practice, new developments in the field may supersede the material published here. Only properly trained and licensed practitioners should provide medical care to patients with respiratory failure. Nothing in this book should be construed as advice regarding the care of a specific patient or group.*

Copyright © 2018, 2012 by William Owens, MD

All rights reserved. This book or any portion thereof may not be reproduced or used in any manner whatsoever without the express written permission of the publisher except for the use of brief quotations in a book review.

Second Edition

Cover Design by Lorien Owens

Published by First Draught Press

Columbia, SC

ISBN 978-0-9852965-4-4

Printed in the United States of America

To Lorien, my best friend and wife,  
And to William, Zach, and Amelia, the best kids I could ever  
hope to have.



# Table of Contents

[Introduction](#)

[Philosophy of Mechanical Ventilation](#)

[Chapter 1: Initial Settings](#)

[Chapter 2: Quick Adjustments](#)

[Chapter 3: Troubleshooting](#)

[Chapter 4: The Eleven Commandments of Mechanical Ventilation](#)

[Chapter 5: Acute Respiratory Failure](#)

[Chapter 6: Monitoring of the Ventilated Patient](#)

[Chapter 7: Arterial Blood Gas Analysis for the Compleat Idiot](#)

[Chapter 8: Assist-Control Ventilation](#)

[Chapter 9: Synchronized Intermittent Mandatory Ventilation](#)

[Chapter 10: Pressure Support Ventilation](#)

[Chapter 11: PEEP and CPAP](#)

[Chapter 12: Trigger and Flow](#)

[Chapter 13: High Frequency Oscillatory Ventilation](#)

[Chapter 14: Airway Pressure Release Ventilation](#)

[Chapter 15: Liberation from Mechanical Ventilation](#)

[Chapter 16: Prolonged Respiratory Failure](#)

[Appendix of Useful Knowledge](#)

[References](#)

[Acknowledgements](#)

[About the Author](#)

# Introduction

So, here you are in the Intensive Care Unit at 3:30 in the morning. The Emergency Department has just admitted a patient to your service—a young man with a rather sudden onset of fever, rigors, and respiratory distress. He had to be intubated in the ED and the ventilator seems to be alarming with a nerve-racking frequency. His chest X-ray looks horrible, with diffuse infiltrates and consolidations. The ICU respiratory therapist looks at you and asks the question you have been dreading since the patient arrived— “Doctor, what vent settings do you want?”

This is a familiar story for those of us who spend a lot of time in the ICU, and an experience that just about every resident has at least once during his or her training. Mechanical ventilation can be intimidating—it has its own terminology, not all of which makes sense; it’s a life-sustaining technology, and misapplication can have serious consequences; and practitioners of mechanical ventilation tend to talk in esoteric ways about what the ventilator is doing. This can confuse even the smartest resident or medical student.

To make things worse, there aren’t a lot of practical resources for busy physicians who just need some quick guidance on how to adjust the ventilator. Don’t get me wrong—there are *plenty* of great textbooks on mechanical ventilation. And, if you have the time, they are well worth reading. The operative word, however, is “time.” Reading a hundred pages on the pros and cons of pressure control ventilation may be a good use of an afternoon in the library but it’s wholly impractical while taking care of patients in a busy ICU. What’s necessary is a how-to guide, and that’s why I’ve written this book. Since there’s only one author, this book will be biased. Not too much, I hope, but I’m not delusional enough to think that my approach is completely objective and based in fact. Like everyone else in medicine, personal anecdote and experience has shaped my practice.

The first part of this user's manual is designed to help you make good decisions quickly. It is broken down into clinical problems with a proposed approach for each. This is something that you can use on the fly. It closes out with the Eleven Commandments of Mechanical Ventilation.

The second part of the book is intended to teach you about mechanical ventilation. The chapters are short, and each can be read easily within 15-20 minutes. Here, you'll learn to speak the language and understand the rationale for why things work and why intensivists do what they do.

At this point, it's necessary for me to point out that while this book is chock-full of great advice, none of it is specific to the care of any individual patient. Have any of your faculty ever told you that the patients don't read the textbook? They're right. Every patient needs an individualized approach. Believe it or not, my lawyer didn't make me write this. *It's just common sense* .

# Philosophy of Mechanical Ventilation

*The art of medicine consists of amusing the patient while Nature takes its course.*

—*Voltaire*

Mechanical ventilation is a wonderful tool. The birth of modern-day critical care occurred in Copenhagen in 1952, when Bjorn Ibsen realized that positive pressure ventilation could save lives during a polio epidemic when the iron lungs (a negative pressure ventilator) were failing. The most common reason for admission to a medical intensive care unit is the need for mechanical ventilatory support. The combination of endotracheal intubation and positive pressure ventilation has likely saved hundreds of thousands, if not millions, of lives.

Likewise, artificial ventilation has prolonged the lives of thousands of people afflicted with spinal cord injuries and devastating neuromuscular diseases. Ventilators attached to wheelchairs permit patients with these conditions to engage in life, to pursue their interests, and to generally live lives that would not have been possible a half-century ago. Truly, this invention has had a positive effect on many, many people.

As is the case with any technology, however, there is the potential for misuse. It is essential that anyone working in an intensive care unit remember the Third Commandment—that the ventilator is a means of support, and not a cure for any condition. In other words, it is folly to believe that the application of mechanical ventilation can reverse chronic lung disease, malignancy, congestive heart failure, or any of the myriad diseases and injuries that result in respiratory failure. The ventilator exists to maintain the respiratory and metabolic functions of the lungs until the patient recovers from his or her illness. It cannot make the patient better by itself. This is actually a point lost on many physicians, who believe that

small tweaks and adjustments to the ventilator will accelerate the patient's recovery from acute respiratory failure.

If it is important for physicians to understand the natural history and trajectory of a patient's disease, it is equally important that the physician present this information to the patient and his family in concise, understandable, and even blunt terms. A life spent connected to a ventilator may be acceptable to a patient with amyotrophic lateralizing sclerosis, who may require mechanical ventilation but can otherwise speak, interact, and engage in what he considers an acceptable quality of life. It is a different matter entirely for a patient suffering from a massive intracerebral hemorrhage who is comatose, and is expected to remain comatose for, if not the rest of his life, a great deal of it. While the patient or his family may consider this to be a worthwhile existence, it behooves the physician to inform them of the stark realities of preserved life on a ventilator (including the medical, social, and financial ramifications) before they pursue this treatment option.

So, what is a dedicated, caring physician, nurse, or respiratory therapist to do? Unsubstantiated optimism can be harmful, but so can overly pessimistic nihilism. Most patients with respiratory failure who recover from the inciting illness or injury will recover; true ventilator dependence, meaning a need for mechanical ventilation more than a year afterward, is rare. Here's what we can do:

1. Protect the lung from iatrogenic injury. Use an evidence- and physiology-based approach to ventilator settings.
2. Promptly and aggressively treat the inciting illness or injury.
3. No disease is effectively treated with starvation. Proper nutritional support is very important.
4. People aren't meant to lie in bed all day. Unless the patient is comatose, in shock, or has profound respiratory failure, it's time to start getting him out of bed and into a chair. Walking, even. I'll add that this, of course, requires a strong dose of common sense. Mobilizing a patient with an open sternum might not be a good idea. But, it's

surprising how many patients lie flat on their backs for their entire ICU stay. Not healthy.

5. When the patient seems to be recovering, start assessing his readiness for extubation every day.
6. Be patient. It might take longer than you think.
7. Once it's evident that the patient will require prolonged mechanical ventilation, get on with the tracheostomy. There's no need to wait an arbitrary number of days.
8. Pay attention to the little things like DVT prophylaxis, skin care, and preventing delirium.
9. Be patient. And....
10. Remember that your patient is a fellow human being with wants, needs, cares, and concerns that may be strikingly similar to your own. He deserves to be spoken to, even if he can't speak back. He deserves respect, even though he may not be able to return that respect. He deserves the basics of human kindness and touch. Remember that he has placed his life in your hands. Your job is not an easy one, and not one that most people can do. The recognition that you have positively affected the life of another person in a way that few can is the greatest reward of this great profession.

# Chapter 1

## Initial Settings

*\*Note on measurements—unless otherwise specified, all airway pressures are measured in cm H<sub>2</sub>O. All tidal volumes are expressed as mL/kg of predicted body weight (PBW).*

### **Modes of Ventilation**

There are several different modes of ventilation, and each ventilator manufacturer has its own (usually trademarked) name for them (PRVC, VC+, CMV with Autoflow, ASV, PAV, Volume Support, and the list goes on and on). This can be intimidating at first—who's to know what to pick? Fortunately, like medications, all of these have a generic name as well. That's all you really need to know, because all of the modes on the different ventilators available for sale will be essentially the same (just with a different trade name).

Each mode of ventilation has its strengths and weaknesses. No mode is perfect, and no mode is useless. It's best to pick the mode that best suits the patient's needs at the time. Each of these modes is discussed in more detail in the following chapters, but here's a brief overview.

### **Assist-Control Ventilation**

Assist-Control Ventilation is the mode of choice in most circumstances. It allows the ventilator to essentially take over the work of breathing and is preferred when a patient has acute cardiac or respiratory failure. It provides full respiratory support. If the patient wants to breathe over the set rate, he can; when he triggers the ventilator, he gets the full breath with minimal effort.

Upside: Takes over the work of breathing; clinician can choose to set a tidal volume (volume control) or an inspiratory pressure (pressure control).

Downside: A tachypneic patient will get the full tidal volume on every breath, so without adequate sedation this could lead

to significant respiratory alkalosis or air trapping. This can be a problem in patients with COPD or asthma.

### **SIMV with Pressure Support**

SIMV also can provide full ventilator support and is a very popular mode. Like Assist Control, the clinician can choose a tidal volume or an inspiratory pressure. The major difference between SIMV and Assist Control is what happens when the patient initiates a breath—in A/C, he gets the full tidal volume; in SIMV, he gets whatever he can pull (usually with the help of pressure support).

Upside: Can take over the work of breathing but allows the patient more spontaneous breathing than in assist-control. Can be useful for weaning support gradually.

Downside: If the machine rate is not set high enough, an unstable patient can get fatigued due to excessive work of breathing. If the pressure support is not set high enough, spontaneous breaths may be fast and shallow, which also leads to fatigue.

### **Pressure Support Ventilation**

PSV doesn't have a set rate—instead, it allows the patient to breathe on his own and “boosts” each breath with a pressure that the clinician selects. It's used in conjunction with CPAP to improve alveolar recruitment. PSV is used in patients who are either intubated for reasons other than cardiac or respiratory failure (altered mental status, jeopardized airway) or for weaning. It can also be used when the patient has a severe metabolic acidosis—if he has a pH of, say, 6.88 and a  $\text{HCO}_3$  of 4, his respiratory drive will be markedly elevated and a mode like assist-control may not be able to meet his metabolic demands.

Upside: Allows the patient to set his own rate and pattern of breathing, which is more comfortable; spontaneous breathing has salutary effects on hemodynamics and VQ matching.

Downside: There's no backup rate, so if the patient goes apneic nothing will happen until the alarms sound. Unstable



patients will fatigue rapidly if the work of breathing is imposed on them, even with high levels of pressure support.

## **Unconventional Modes**

Airway pressure release ventilation (APRV) and high frequency oscillatory ventilation (HFOV) are used to treat severe hypoxemia. They are seldom the first-line option for acute respiratory failure and will be discussed later in the book. For now, just focus on the modes already listed (A/C, SIMV, PSV).

## **Ventilator Settings Based on Pathophysiology**

### **Restrictive Lung Disease**

Examples: ARDS, aspiration pneumonitis, pneumonia, pulmonary fibrosis, pulmonary edema, alveolar hemorrhage, chest trauma

Restrictive lung diseases are associated with a reduction in respiratory system compliance. The lungs want to collapse. In other words, it's hard to get air in and easy to get air out. The ventilation strategy is to recruit vulnerable alveoli, prevent cyclical alveolar closure, provide adequate oxygenation, and to minimize volutrauma from overdistension.

The initial mode should be one that takes over the work of breathing for the patient. Assist-control, using either volume-controlled or pressure-controlled ventilation, is the mode of choice.

For volume-controlled ventilation:

1. Tidal volume of 6 mL/kg PBW
2. Rate of 14-18 breaths per minute, with a decelerating flow pattern
3. FiO<sub>2</sub> 100% at first; reduce to 60% if SpO<sub>2</sub> ≥ 88%
4. PEEP of 5-10 cm H<sub>2</sub> O, depending on the degree of hypoxemia. Remember, the more opacification in the lungs

on the chest X-ray, the more PEEP will be needed to reduce intrapulmonary shunting.

5. If hypoxemia persists, increase the PEEP until the SpO<sub>2</sub> is 88% or better. Don't exceed 20.
6. After adjusting the PEEP, check the plateau pressure. If the P<sub>PLAT</sub> is more than 30 cm H<sub>2</sub> O, decrease the tidal volume until the P<sub>PLAT</sub> is less than 30. Don't go below 4 mL/kg PBW.

For pressure-controlled ventilation:

1. PEEP of 5-10 cm H<sub>2</sub> O, depending on the degree of hypoxemia
2. FiO<sub>2</sub> 100%; reduce to 60% if SpO<sub>2</sub> ≥ 88%
3. Driving pressure (or inspiratory pressure) of 15 cm H<sub>2</sub> O
4. Rate of 14-18 breaths per minute
5. Inspiratory time adjusted to keep the I:E ratio 1:1.5 or higher. The I-time is usually 1.0-1.5 seconds. A rate of 20 and an I-time of 1.0 seconds has an I:E ratio of 1:2 (one second inspiration, two seconds expiration). A rate of 15 with an I-time of 1.5 seconds has an I:E ratio of 1:1.67 (1.5 seconds inspiration, 2.5 seconds expiration). This is displayed on the ventilator screen.
6. If hypoxemia persists, increase the PEEP until the SpO<sub>2</sub> is 88% or better. Don't exceed 20 cm H<sub>2</sub> O.
7. Look at the exhaled tidal volume. If it exceeds 6 mL/kg, lower the driving pressure until the tidal volume is in the 4-6 mL/kg range.

After initiating ventilation, check an arterial blood gas. 15-20 minutes is enough time for gas exchange to equilibrate.

Make changes in the respiratory rate to change the PaCO<sub>2</sub> (a higher rate lowers the PaCO<sub>2</sub>, and vice versa). Leave the tidal volume in the 4-6 mL/kg range, keeping the P<sub>PLAT</sub> (volume-control) or P<sub>INSP</sub> (pressure control) at 30 cm H<sub>2</sub> O or less. Remember that lung protection is more important than normal ventilation—a pH of 7.15 or better is acceptable and it's not

worth injuring the lungs with overdistension (in the form of high tidal volumes) to get a normal pH or PaCO<sub>2</sub> .

Lower the FiO<sub>2</sub> , keeping the PaO<sub>2</sub> between 55 and 70 mm Hg and the SpO<sub>2</sub> between 88% and 94%. There's nothing to gain from keeping the PaO<sub>2</sub> above this range, with few exceptions. Patients with traumatic brain injury sometimes require a higher PaO<sub>2</sub> , usually in conjunction with brain tissue oxygen monitoring. Victims of carbon monoxide poisoning also benefit from breathing 100% oxygen.

## **Obstructive Airways Disease**

Examples: COPD, Asthma

Obstructive lung disease is associated with an increase in respiratory system compliance and an obstruction to expiratory airflow. It's easy to get air in, but hard to get it out.

The ventilation strategy is to rest the respiratory muscles, provide adequate oxygenation, and reduce hyperinflation.

Assist-control ventilation is usually the mode of choice, and volume-control is preferable to pressure-control. SIMV with PS can also be used, however, as long as the rate and PS are set high enough to prevent tachypnea and fatigue. High airway resistance and high peak inspiratory pressures characterize exacerbations of COPD and asthma, even though the P<sub>PLAT</sub> may be significantly lower. Using pressure-control in this situation leads to very low tidal volumes. Volume-control guarantees that the desired tidal volume will be delivered.

1. Tidal volume of 8 mL/kg PBW. Lower tidal volumes can lead to air trapping and worsening hyperinflation.
2. Rate of 10-14 breaths per minute
3. Inspiratory time adjusted to keep an I:E ratio of 1:3 or higher. In obstructive airways disease, air gets in easily but has a hard time getting out due to narrow, inflamed bronchioles and bronchi. Give the air some time to escape.
4. With asthma, applied PEEP will worsen hyperinflation. With COPD, PEEP can be used to splint open airways that are prone to collapse. This is because COPD is

characterized by dynamic airway obstruction, while the obstruction is fixed in an asthma exacerbation. A good starting point for both is a PEEP of 0, or ZEEP—zero applied end-expiratory pressure.

5.  $\text{FiO}_2$  of 100% to start; lower this to 60% as long as the  $\text{SpO}_2$  remains 88% or better.

Sometimes, patients with COPD or asthma will remain tachypneic despite adequate sedation. In assist-control, every patient-triggered breath delivers a full tidal volume, and this can lead to air trapping or severe respiratory alkalosis. If this is the case, switching the mode to SIMV may help.

### **Severe Metabolic Acidosis**

Examples: Salicylate poisoning, septic shock, toxic exposures, acute renal failure, diabetic ketoacidosis

The normal response of the respiratory system in the setting of metabolic acidosis is to hyperventilate.  $\text{CO}_2$  is a volatile acid and the lungs can rapidly eliminate this acid from the body in an attempt to bring the pH closer to normal. In a patient with a  $\text{HCO}_3^-$  of 4 mEq/L, for example, the  $\text{PaCO}_2$  will be 14-15 mm Hg if there's appropriate respiratory compensation. This requires a very high minute ventilation to accomplish.

It is very difficult to set the ventilator to provide a high minute ventilation, even if you set the rate to be 30-35 and the tidal volume to be 800-1000 mL. Patients with severe metabolic acidosis will often breathe in when the vent is trying to breathe out, and vice versa—this leads to significant patient-ventilator dyssynchrony and alarming of the machine. More consequentially, the volume and pressure alarms that are normally helpful will actually work against the patient by limiting the minute ventilation that can occur.

Consider the aforementioned example—a patient who has a pH of 6.88 and a  $\text{HCO}_3^-$  of 4 needs a  $\text{PaCO}_2$  of 14-15. If he's intubated and sedated, and the vent settings are put in the “usual” range, his  $\text{PaCO}_2$  may rise to 25-30. In the setting of

severe acidemia, this increase in CO<sub>2</sub> will cause his pH to fall to 6.6 or so, which will most likely lead to a cardiac arrest.

The best way to deal with this situation is to let the patient's naturally high respiratory drive work in his favor.

1. Use the *bare minimum* of sedation to intubate and avoid neuromuscular blockers entirely.
2. Set the vent mode to be Pressure Support Ventilation.
3. CPAP (a.k.a. PEEP) 5-10 cm H<sub>2</sub> O, depending on the degree of hypoxemia
4. Pressure Support (PS) of 10-15 cm H<sub>2</sub> O. Adjust if needed to allow the patient to breathe comfortably; most of the time, 10 cm is enough PS.
5. Allow the patient to have a minute ventilation of 18-25 L/min. Don't be alarmed to see him pull spontaneous volumes of 1000-2000 mL. The high minute ventilation will keep the pH up while the cause of the metabolic acidosis is being treated.

## **Key Ventilator Concepts for Other Clinical Situations**

- The left ventricle likes PEEP—increasing the intrathoracic pressure lowers preload and afterload, which is beneficial in acute cardiac failure due to left ventricular dysfunction (either systolic or diastolic).
- The right ventricle, on the other hand, doesn't care for PEEP very much. Increased intrathoracic pressure can increase pulmonary vascular pressures and stress the thin-walled RV. In situations where RV failure is present (massive pulmonary embolism, worsening pulmonary hypertension), use more FiO<sub>2</sub> and less PEEP (ideally 10 cm or less) to maintain oxygenation.
- When there is acute brain injury, be it from stroke, hemorrhage, trauma, or something else, the priority with mechanical ventilation is the maintenance of adequate oxygenation. Aim for an SpO<sub>2</sub> of 94-98% and a PaO<sub>2</sub> of 80-100 mm Hg. PEEP may increase the intracranial

pressure, but it seems to be significant only when the PEEP is 15 cm or higher. Hypoxemia, on the other hand, definitely increases intracranial pressure. Therefore, use what it takes to maintain adequate cerebral oxygenation.

- Hyperventilation ( $\text{PaCO}_2 < 32$ ) lowers intracranial pressure, but it works by causing cerebral vasoconstriction. In other words, it works by making the brain ischemic. This may be helpful if a patient is about to herniate and you need 5 minutes to get the mannitol in, or 10 minutes to get to the OR. Prolonged hyperventilation, on the other hand, worsens brain ischemia and has no lasting effect on intracranial hypertension. Aim for a normal (35-40)  $\text{PaCO}_2$ .

# Chapter 2

## Quick Adjustments

These are ways to adjust the ventilator based on the arterial blood gas. Obviously, the patient's condition should dictate what's done. The adjustments are in order of preference.

### **PaO<sub>2</sub> Too Low**

Assist-Control, SIMV: increase PEEP, increase FiO<sub>2</sub>

APRV: increase P<sub>HIGH</sub>, increase T<sub>HIGH</sub>, increase FiO<sub>2</sub>

HFOV: increase mean airway pressure, increase FiO<sub>2</sub>

### **PaCO<sub>2</sub> Too High**

Volume Assist-Control or SIMV: increase rate, increase tidal volume

Pressure Assist-Control or SIMV: increase rate, increase driving pressure

APRV: increase the gradient between P<sub>HIGH</sub> and P<sub>LOW</sub>, decrease T<sub>HIGH</sub>, increase T<sub>LOW</sub>

HFOV: decrease the frequency, increase the amplitude, increase T<sub>I</sub> %, allow a 5 cm cuff leak

### **PaCO<sub>2</sub> Too Low**

Volume Assist-Control or SIMV: decrease rate, lower tidal volume

Pressure Assist-Control or SIMV: decrease rate, lower driving pressure

APRV: increase T<sub>HIGH</sub>, lower P<sub>HIGH</sub>, decrease T<sub>LOW</sub>

HFOV: increase the frequency, lower the amplitude, decrease T<sub>I</sub> %

# Chapter 3

## Troubleshooting

These are problems that you'll be called about. As always, the first thing you should do is examine the patient. Remember your ABCs and use this guide to help you figure out what's wrong.

### Problem: High Peak Airway ( $P_{AW}$ ) Pressures

Your first step should be to perform an inspiratory pause and measure the plateau pressure ( $P_{PLAT}$ ). The plateau pressure represents the alveolar pressure, while the peak pressure is a combination of the alveolar pressure and airway resistance.

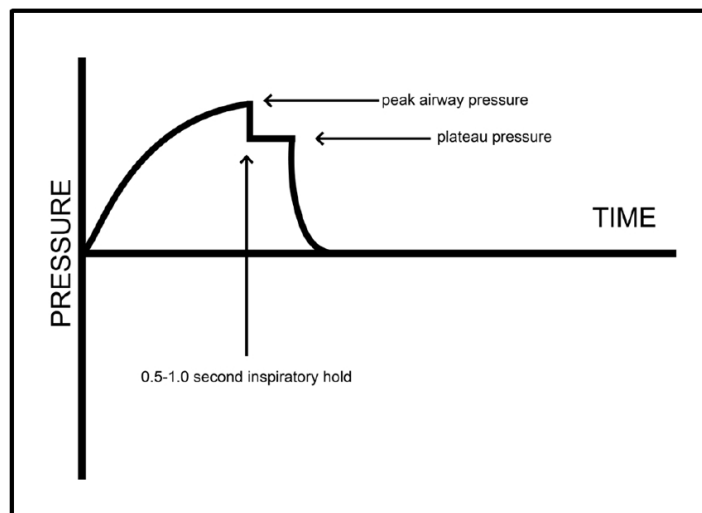

The plateau pressure, or  $P_{PLAT}$ , represents the equilibration of pressures throughout the lungs when flow is stopped. This is the best assessment of the alveolar pressure.

The *difference* between the peak airway pressure and the plateau pressure represents the resistance of the conducting airways. This is normally  $< 5 \text{ cm H}_2\text{O}$ .



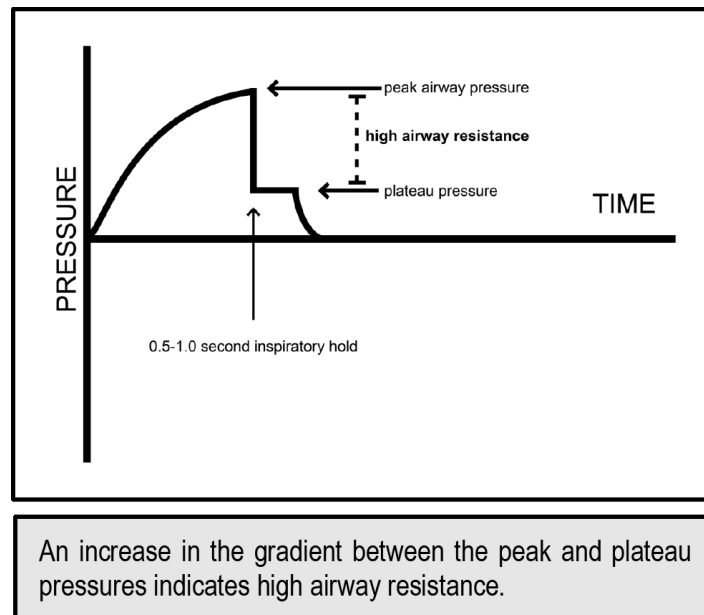

High  $P_{AW}$  , Low  $P_{PLAT}$  —this means the problem is high airway resistance.

- Kinked endotracheal tube—unkink the tube
- Mucus plugging—pass a suction catheter
- Bronchospasm—inhaled bronchodilators
- Too narrow of an endotracheal tube—change the tube, or accept higher  $P_{AW}$

High  $P_{AW}$  , High  $P_{PLAT}$  —this means the problem is in the lungs.

- Mainstem intubation—pull the endotracheal tube back into the trachea
- Atelectasis of a lobe or lung—chest percussion, or bronchoscopy to open up the airway
- Pulmonary edema—diuretics or inotropes
- ARDS—use a lower tidal volume, higher PEEP strategy
- Pneumothorax—chest tube

## **Problem: Dynamic Hyperinflation (Auto-PEEP)**

This is usually due to inadequate time for exhalation. High airway resistance (bronchospasm, COPD, mucus plugging) makes it worse. On exam, the patient's abdominal muscles will contract forcefully during exhalation. Neck veins may be distended, and you may hear loud wheezing. The ventilator's expiratory flow waveform will not return to the baseline of zero flow.

- Lower the ventilator rate, usually between 10-14 breaths per minute
- Shorten the inspiratory time to keep the I:E ratio in the 1:3 – 1:5 range
- Keep the tidal volume in the 6-8 mL/kg range— a higher tidal volume will often slow the patient's spontaneous respirations
- Increase the inspiratory flow to 60-80 liters per minute if the patient seems to be “air hungry”
- Adequate sedation with narcotics will help blunt a tachypneic response
- Treat bronchospasm with inhaled bronchodilators and systemic steroids

## **Problem: Sudden drop in SpO<sub>2</sub>**

New or worsening hypoxemia is always cause for alarm. The first step is to exclude mechanical problems or tube displacement.

- Disconnect the patient from the ventilator and bag him
- Make sure the tube is in place (use either color-change or waveform capnometry if there's any

doubt about the tube) and that breath sounds are present and equal

- Obtain an arterial blood gas
- Chest X-ray—this will show you worsening infiltrates, pneumothorax, pulmonary edema, atelectasis, or new effusions
- Always consider pulmonary embolism as a cause for new hypoxemia in an ICU patient, and have a low threshold for diagnostic studies
- Absent breath sounds on one side—pull the endotracheal tube back a few centimeters
- Absent breath sounds on one side, even with the tube in the right place—think pneumothorax, or mucus plugging with complete atelectasis of the lung
- Tension pneumothorax should be suspected if breath sounds are absent on one side and if the patient is hypotensive. Distended neck veins and tracheal shift away from the affected side are supportive but not always seen. The treatment is immediate needle decompression and placement of a chest tube.

### **Problem: Fighting the Ventilator**

Before sedating or paralyzing a patient for “fighting the ventilator,” you should always check **TSS** —**T**ube, **S**ounds, **S**ats. Make sure that the endotracheal tube is in place and not obstructed, that breath sounds are present and equal, and that the patient is not hypoxemic. Other things you should look for are:

- Dynamic hyperinflation (see above for how to treat this)
- Untreated pain, especially in trauma and surgical patients
- Make sure the vent is providing an adequate rate and tidal volume
- Switch to assist-control ventilation, if the patient is getting fatigued
- Search for other causes of distress—cardiac ischemia, fever, abdominal distension, neurologic deterioration, etc.

### **Problem: Change in $E_T CO_2$**

First, look at the waveform. If there is no waveform, it means one of three things:

- The endotracheal or tracheostomy tube is not in the trachea
- The tube is completely occluded
- The  $E_T CO_2$  sensor is faulty

Obviously, the first two are serious emergencies and should be dealt with immediately. The third is diagnosed only after ruling out the first two.

If the waveform is present, then look at the  $E_T CO_2$  value. With a significant change in the  $E_T CO_2$ , an arterial blood gas should be obtained as well to see what the  $PaCO_2$  is.

Rising  $E_T CO_2$  and  $PaCO_2$  —this indicates either increased  $CO_2$  production or alveolar hypoventilation.

- Fever

- Malignant hyperthermia
- Thyrotoxicosis
- Suppressed respiratory drive without a sufficient ventilator backup rate

Falling  $E_T$   $CO_2$  with unchanged or rising  $PaCO_2$  —the widening gradient between the two suggests an increase in dead space ventilation.

- Pulmonary embolism
- Falling cardiac output (cardiogenic or hypovolemic shock)
- Dynamic hyperinflation with autoPEEP

Falling  $E_T$   $CO_2$  and falling  $PaCO_2$  —indicates an increase in alveolar ventilation.

- Pain
- Agitation
- Fever
- Sepsis

# Chapter 4

## The Eleven Commandments of Mechanical Ventilation

- I. Thou shalt mind thy patient's **COMPLIANCE**, and measure it daily.
  - Compliance is the change in volume divided by the change in pressure. **Dynamic** compliance is the exhaled tidal volume divided by the dynamic change in pressure (peak minus PEEP). **Static** compliance is the exhaled tidal volume divided by the static pressure differential (plateau minus PEEP). If there's a big difference between the two, increased airway resistance is usually to blame.
  - Normal respiratory system compliance is about 100 mL/cm H<sub>2</sub> O; normal for a ventilated patient is 70-80.
  - Falling compliance can mean fluid overload, developing pneumonia or ARDS, pneumothorax, or many other bad things.
  - Improving compliance usually means the patient is getting better, at least from a pulmonary mechanics point of view.

II. 'Tis nobler to **INTUBATE** and **VENTILATE** than to needlessly allow a patient to suffer the slings and arrows of critical illness.

- Intubating a critically ill patient is never a sign of weakness; rather, it is a sign of decisiveness.
- A few of the indications for intubation are refractory hypoxemia, hypercapnia, a jeopardized airway, shock, and great metabolic disturbances.

III. Thy mechanical ventilator is merely a means of **SUPPORT** , and offers no curative properties in itself.

- It's a mistake to think that the ventilator itself can help the patient. It merely allows the patient to survive until he recovers.
- A ventilator has only three therapeutic benefits:
  1. Guaranteed delivery of high levels of oxygen
  2. Positive pressure to reduce intrapulmonary shunt (from atelectasis, ARDS, pneumonia, pulmonary edema, etc.)
  3. Providing the work of breathing until the patient is able to do it himself

IV. Thou shalt be familiar with the **ABUNDANCE** of **MODES** , as no one is perfect for every situation and no one is completely useless.

- While you may have your preferred mode, remember that you can ventilate most any patient with any given mode as long as you set the ventilator properly.
- Some patients will seem to prefer one mode over another. I don't know why this happens, but it does. Deal with it and don't be afraid to find out what vent settings suit the patient best.

V. Thou shalt mind the **TIDAL VOLUME** closely and without fail, lest the lungs suffer from excessive distension.

- Of all the studies done on mechanical ventilation in acute lung injury and ARDS, the *only* thing that seems to affect survival is the use of excessive tidal volumes.
- Your resting tidal volume is 4-6 mL/kg of your predicted body weight. Your patient's should be as well.
- The patient's actual body weight should not be used for this calculation. Carry a table, memorize the formula, or download an app to figure out the PBW. You will need the patient's height and gender (both usually easy to obtain).
- Be wary of physicians who confidently tell you that the plateau pressure is more important, or that 7, or 8, or 9 mL/kg is better than 6—while they may be right, they possess no evidence to support their claims.



VI. Thou shalt **OPEN** thy patient's lungs and **KEEP THEM OPEN**.

- Positive end-expiratory pressure is used to recruit collapsed alveoli and to prevent them from closing during exhalation.
- This helps to restore at least some functional residual capacity and reduce intrapulmonary shunt.
- A general rule is that if you can see white stuff in the lungs on the chest X-ray, increasing the PEEP is better than using high levels of oxygen for correcting hypoxemia.

VII. For the **PERFECT ABG** is a mythical creature and should not be pursued lest the patient suffer grave harm in the form of barotrauma and volutrauma.

- It's more important to protect the patient from harm than to blindly pursue a "normal" blood gas, especially if it means using excessively high tidal volumes or ventilator pressures.
- All decisions regarding ventilator settings should be made with the whole patient in mind. Permissive hypercapnia is perfectly acceptable in status asthmaticus but not in the patient with cerebral edema.
- In most cases, a PaO<sub>2</sub> of 55 is adequate.

VIII. Thou shalt not allow thy shocked patient to **FATIGUE**, but instead provide the ventilator support necessary for him to recover.

- In the setting of shock, hemorrhage, or severe sepsis, work of breathing can account for 40-50% of a patient's basal energy expenditure. Mechanical ventilation should be used to take over this work until the underlying cause has been treated adequately.
- Assist-control ventilation is one of the best ways to do this and is the preferred mode most of the time in these situations.
- There are many theories about exercising the diaphragm and allowing the patient to “work out” on SIMV or CPAP/PSV, but no one has proven that it helps (and it may in fact be harmful).
- Assist-control, with a daily spontaneous breathing trial if indicated, is a simple formula that is also very effective at minimizing the time a patient stays on the ventilator.

IX. Thou shalt seek out **DYNAMIC**

**HYPERINFLATION** wherever it may be found, and treat it, for 'tis an insidious beast!

- Hyperinflation is also known as auto-PEEP or breath stacking. It occurs when the patient can't get all of the air out before the next breath starts.
- If unchecked, dynamic hyperinflation can lead to discomfort, hypercapnia, hypotension, and even PEA arrest. Suspect it in all patients on the vent who have obstructive lung disease and look for it even in patients who don't. If

the PaCO<sub>2</sub> keeps going up as the rate is increased, hyperinflation is the likely culprit.

- Treat this condition by slowing the ventilator rate, extending the time for exhalation, and treating bronchospasm. A small measure of applied PEEP may help prevent airway collapse during exhalation.

X. Verily, a **SPONTANEOUS BREATHING TRIAL** should be performed readily and daily on all patients whose conditions permit.

- No one is good enough to reliably predict which patients can be extubated on a given day.
- A spontaneous breathing trial (SBT) should be done whenever the reason for intubation (severe hypoxemia, coma, shock, bronchospasm) has resolved. The SBT can be in the form of a T-piece or low-level pressure support ventilation.
- Don't be afraid to act on the results of the trial. If the patient looks ready, extubate him. The occasional reintubation is not a sign of failure. In fact, if you never reintubate a patient, you're probably waiting too long to extubate the others.

XI. Thy Respiratory Therapist is the ordained **KEEPER OF THE VENT** and should be treated with utmost esteem.

- Do not make any changes to the ventilator settings without the RT present. If you want

to experiment with different settings to see what happens, call the RT first.

- While you may know what you're doing, you probably don't know how to reset all the alarms, sensors, etc. that have to be adjusted when significant changes are made. It's also the RT's responsibility, and if you make changes without notifying him/her it makes a difficult job even harder.

# Chapter 5

## Acute Respiratory Failure

Acute respiratory failure is one of the most common reasons for admission to the intensive care unit. The majority of cases will require some sort of positive pressure ventilation, either from a mask (CPAP, BiPAP) or an endotracheal tube. Obviously, this is important. There's a reason why A and B come first in the ABC's of resuscitation—without adequate gas exchange (oxygenation being the most important), the patient can die within minutes. Many times, the physician has to treat acute respiratory failure before he can figure out the whys and hows of what happened. That's OK! Once the patient is stabilized, however, the detective work begins.

Acute respiratory failure, according to the textbook by Parrillo and Dellinger, is “the inability of the respiratory system to meet the oxygenation, ventilation, or metabolic requirements of the patient.” <sup>1</sup>

Let's break this definition down:

- “The respiratory system”: More than the lungs. Obviously, the lungs are the major players, but disorders of the upper airway, chest wall, cardiovascular system, and neurologic system can cause significant respiratory dysfunction.
- “Oxygenation requirements”: Type I respiratory failure is defined as a PaO<sub>2</sub> less than 60 mm Hg. The first priority in treating patients with acute respiratory failure is to correct hypoxemia!
- “Ventilation requirements”: Type II respiratory failure is a PaCO<sub>2</sub> greater than 50 mm Hg, *with* a pH less than 7.30. The pH is important in distinguishing acute from chronic respiratory failure.

- “Metabolic requirements”: This is often forgotten, but the lungs have a key role in maintaining metabolic homeostasis. CO<sub>2</sub> clearance by the respiratory system is adjusted to balance out metabolic derangements. Likewise, oxygen intake and delivery to the tissues begins in the lungs.
- “Of the patient”: Probably the most important part of the definition. A particular patient may have “normal” blood gas numbers but still require respiratory support. Conversely, another patient may have *terrible* numbers but not require any kind of acute intervention. Like everything else in medicine, start with the history and physical exam. *In the future, patients can be plugged into a machine that will immediately analyze all of their medical problems and print out a list for the physician. I saw that on Star Trek. Until then, we still have to do an H&P.*

## Common Diagnostic Testing

**Arterial Blood Gas:** to determine whether or not respiratory failure is present, assess the metabolic status of the patient, and to determine (in part) the cause of respiratory failure. Co-oximetry can help diagnose carbon monoxide poisoning and methemoglobinemia.

**Chest X-ray:** to diagnose cardiac failure, pneumonia, pneumothorax, pleural effusion, and a whole lot of other diseases. Also, helpful if it's normal—a clear X-ray and hypoxemia should make you consider a pulmonary embolism.

**CT Chest:** for a better look at the thoracic structures; if done with angiographic technique, it can diagnose pulmonary embolism and aortic dissection.

**Bronchoscopy:** to diagnose inhalational injury, foreign body, upper airway obstruction, pneumonia, and alveolar hemorrhage.

## Hypoxemic Respiratory Failure

Hypoxemia poses the most immediate threat to the patient. Vital organs like the brain, heart, etc. depend on a continuous delivery of oxygen to use for energy production. That's why just about all resuscitation efforts begin with giving the patient

supplemental oxygen (by nasal cannula, mask, or endotracheal tube). The pathophysiologic causes of hypoxemia are:

1. Shunt
2. Ventilation-Perfusion (VQ) Mismatch
3. Diffusion limitation
4. Dead Space
5. Low  $F_{iO_2}$  (fraction of inspired oxygen)
6. Low  $P_B$  (barometric pressure)
7. Alveolar hypoventilation

Of the things in this list, low  $F_{iO_2}$  and low  $P_B$  are the easiest to rule in or out. Low  $F_{iO_2}$  is seen in house fires (from consumption of oxygen by the flames) and anesthetic gas mishaps. Low  $P_B$  includes things like airplane cabin depressurization and being at extreme altitude. Look around—if you're not in an airplane, the building isn't on fire, and you're not on top of a mountain, these can be discarded from the differential diagnosis. Good! That leaves us with five things to worry about instead of seven. Diffusion limitation is really significant in only a few diseases like pulmonary alveolar proteinosis—most of the time the problem is VQ mismatch. Down to four.

Sorry to introduce math into a clinical discussion, but it's inevitable. If you want to do the job you must have the tools, and one important tool in this field is the *Alveolar Gas Equation*. This equation predicts what the alveolar pressure of oxygen should be.

### Alveolar Gas Equation

$$P_{A O_2} = [(P_B - P_{H_2O}) \times F_{iO_2}] - (P_{aCO_2} / RQ)$$

where  $P_{A O_2}$  is the partial pressure of oxygen in the alveolus,  $P_B$  is barometric pressure (760 mm Hg at sea level),  $P_{H_2O}$  is the partial pressure of water in humidified air (47 mm Hg), and the RQ is the ratio of  $CO_2$  production to oxygen consumption. The RQ in most people is 0.8.

Simplified for a patient breathing room air ( $F_{iO_2}$  of 21%), the equation reads

---

$$P_A O_2 = 150 - 1.2(PaCO_2)$$

For a normal PaCO<sub>2</sub> of 40 mm Hg, the P<sub>A</sub> O<sub>2</sub> should be 102 mm Hg.

Normally, there is a small difference between the partial pressure of oxygen in the alveoli and that seen in arterial blood (the PaO<sub>2</sub>). This is called the A-a gradient, and it represents the small fraction of blood that doesn't participate in gas exchange because of bronchopulmonary anastomoses. The normal gradient is less than 10 mm Hg, but this increases with age. It can also increase with supplemental oxygen. The predicted A-a gradient while breathing 100% oxygen can be as high as 110 mm Hg.

Why is this important? Well, go back to your basic chemistry. The partial pressure of all of the gases in the alveolar space can only add up to the total pressure of the air. Therefore, if the PaCO<sub>2</sub> is elevated, the P<sub>A</sub> O<sub>2</sub> has to go down. Only so many marbles in the jar, so to speak. If the P<sub>A</sub> O<sub>2</sub> goes down, the PaO<sub>2</sub> falls as well. Hypoxemia can be due solely to hypercarbia if the PaCO<sub>2</sub> gets high enough, and *a normal A-a gradient means that there is no problem with the lungs or the pulmonary circulation*. The hypoxemia is a result of inadequate ventilation alone (pure Type II respiratory failure). If the A-a gradient is widened, then there must be some venous admixture. The three mechanisms of venous admixture are shunt, dead space, and VQ mismatch.

## Shunt

Shunt is easy to visualize—blood passing from the right side of the heart to the left side of the heart through areas where there is no ventilation whatsoever. The V/Q ratio is zero. A shunt can be intracardiac or intrapulmonary. The gas exchange abnormality with shunt is profound hypoxemia with preserved ventilation. The PaCO<sub>2</sub> doesn't begin to rise until the shunt fraction exceeds 40-50% of the pulmonary blood flow. The normal shunt fraction is less than 3%.

Intracardiac shunts in adults include uncorrected atrial septal defects and ventricular septal defects. The Eisenmenger



Syndrome is a VSD with shunt reversal (it begins left-to-right, but as the right ventricle hypertrophies the shunt becomes a right-to-left one and the patient becomes hypoxemic).

Pulmonary shunts are caused by something preventing inspired gas from reaching alveoli. Examples include atelectasis, ARDS, pulmonary edema, and consolidation from pneumonia.

Shunt is characterized by hypoxemia resistant to correction. As the shunt fraction increases, the hypoxemia will get worse despite breathing high levels of oxygen. With a shunt fraction of 50%, even the administration of 100% oxygen will rarely take the PaO<sub>2</sub> above 60 mm Hg. <sup>2</sup> Therefore, the treatment of hypoxemic respiratory failure resulting from a shunt requires more than supplemental oxygen. Positive pressure ventilation to recruit and stabilize collapsed lung units is required.

The shunt fraction can be calculated if the mixed venous oxygen content can be sampled using a pulmonary artery catheter (see Appendix for the equation). This has to be done with the patient breathing 100% oxygen to eliminate the contribution of VQ mismatch to the hypoxemia. Because the equation is cumbersome and requires invasive testing, it's useful to have a shortcut. The P/F ratio is calculated by dividing the PaO<sub>2</sub> by the FiO<sub>2</sub>. For example, say a patient has a PaO<sub>2</sub> of 100 mm Hg on 60% oxygen. His P/F ratio is 100/0.6, or 167. A P/F ratio less than 200 suggests a shunt fraction greater than 20%.

## **VQ Mismatch**

Normal cardiac output is 5 L/min. Normal minute ventilation (rate × tidal volume) is 4 L/min. The average ventilation-perfusion ratio, then, is 4/5 or 0.8. As the metabolic demands of the body increase, cardiac output and minute ventilation increase accordingly. Areas that are poorly ventilated don't get much blood flow, though, because of hypoxic pulmonary vasoconstriction.

In every other organ system, hypoxia results in vasodilatation. In the lungs, however, alveolar hypoxia causes vasoconstriction. This is a good thing—why send blood to lung units that don't have a whole lot of oxygen to drop off to the red blood cells? When this balance is lost, VQ mismatch occurs and leads to hypoxemia. This is also the reason why patients with COPD and chronic CO<sub>2</sub> retention get a respiratory acidosis when someone gives them high levels of oxygen.

Certain disease states can alter airway caliber and tone and affect gas delivery to the alveoli, which results in lung units which are more perfused than ventilated—a VQ ratio less than 0.8. Examples of this are asthma, COPD, interstitial lung disease, tracheobronchitis, and pneumonitis. Other diseases may impede proper blood flow to ventilated units, causing more ventilation than perfusion and a VQ ratio of more than 0.8. This can be seen with chronic thromboembolic disease, vasculitis, and overdistension of alveoli during positive pressure ventilation. Patients who are supine and on a ventilator have VQ mismatch owing to the air going anterior and the blood going posterior due to gravity.

VQ mismatch is the most common cause of hypoxemic respiratory failure and usually corrects readily with supplemental oxygen. Even severe cases of VQ mismatch are responsive to breathing 100% oxygen. Inability to correct the PaO<sub>2</sub> with high levels of oxygen suggests a shunt.

## **Dead Space Ventilation**

Dead space is the opposite of shunt—the alveoli are ventilated but there is absolutely no perfusion. The VQ ratio is  $\infty$ . Dead space is seen with large pulmonary embolism, venous air embolism, and low cardiac output. It can also be seen with significant overdistension of alveoli during positive pressure ventilation and dynamic hyperinflation in patients with COPD. The gas exchange abnormality seen with dead space ventilation is both hypoxemia and hypercarbia. The CO<sub>2</sub> is not cleared because the venous blood never comes in contact with alveoli.

Remember that everyone has anatomic dead space, which refers to the trachea and large airways that hold air but don't participate in gas exchange. This is usually 150-180 mL, about 1 mL for every cm in height. This volume is part of the minute ventilation and should account for less than 30% of the tidal volume ( $V_D / V_T \leq 0.3$ ). Rapid shallow breathing can increase the proportion of the minute volume that is dead space.

For example, a patient with a tidal volume of 500 mL has an anatomic dead space of 150 mL and a  $V_D / V_T$  ratio of 0.3. His respiratory rate is 12, for a minute volume of 6 L/min (of which 1.8 L is wasted dead-space ventilation and 4.2 L is alveolar ventilation). If his respiratory rate increases to 30 and his tidal volume drops to 200 mL, he still has the same minute volume of 6 L/min. His dead space is still 150 mL per breath, though, which means that 4.5 L/min ( $30 \times 150$  mL) of his minute ventilation is wasted, leaving only 1.5 L/min for alveolar ventilation. His  $V_D / V_T$  ratio is now 0.75. In this case, the  $\text{PaCO}_2$  would rise and the  $\text{PaO}_2$  would fall due to alveolar hypoventilation.

Tachypnea and labored respirations with a normal  $\text{PaCO}_2$  usually indicates increased dead space and a relative alveolar hypoventilation. This is one of the earliest signs of impending respiratory failure. It is nearly impossible to determine the  $\text{PaCO}_2$  with any kind of accuracy by clinical exam, so arterial blood gas measurements are essential.

## **Hypoxemia vs. Hypoxia**

Hypoxemia refers to a  $\text{PaO}_2$  less than 60 mm Hg. Hypoxia refers to inadequate delivery of oxygen to tissues or ineffective cellular utilization of oxygen, leading to anaerobic metabolism. It's possible to be hypoxemic but not hypoxic, and it's also possible to be hypoxic but not hypoxemic. Of course, you can be hypoxemic and hypoxic, or neither hypoxic nor hypoxemic. Clear enough?

To better understand this, we have to consider how oxygen is delivered to the tissues. Oxygen is bound to hemoglobin and carried to the capillary beds, where it is

unloaded into the cellular milieu; the deoxygenated hemoglobin then picks up CO<sub>2</sub> and takes it back to the lungs to be excreted. Since 97% of the oxygen in the bloodstream is bound to hemoglobin, it makes more sense to focus on the percentage of hemoglobin saturated with oxygen than the partial pressure of oxygen in plasma.

## Oxygen Content Equation

$$\text{CaO}_2 = 1.34 (\text{Hgb}) (\text{SaO}_2) + 0.003(\text{PaO}_2)$$

where CaO<sub>2</sub> is the content of oxygen in arterial blood, expressed in mL O<sub>2</sub> /dL blood; Hgb is in g/dL; SaO<sub>2</sub> is the arterial saturation of oxygen; and PaO<sub>2</sub> is the partial pressure of oxygen in plasma.

For a normal person with hemoglobin of 15 g/dL, SaO<sub>2</sub> of 100%, and PaO<sub>2</sub> of 100 mm Hg, the CaO<sub>2</sub> is 20.4 mL O<sub>2</sub> /dL blood. The oxygen dissolved in plasma contributes 0.3 mL O<sub>2</sub>, or less than 1.5% of the total.

Oxygen delivery is the CaO<sub>2</sub> multiplied by the cardiac output. It's necessary to multiply this by 10, since CaO<sub>2</sub> is measured in deciliters and cardiac output is measured in liters. A normal person with a cardiac output of 5 L/min has an oxygen delivery (DO<sub>2</sub>) of 1020 mL O<sub>2</sub> /min.

Looking at the above equations, you can see that the most important factors governing oxygen delivery are the cardiac output, hemoglobin content, and the arterial oxygen saturation. The PaO<sub>2</sub> plays a minor role.

## Four Types of Hypoxia

**Hypoxemic:** low SaO<sub>2</sub> leading to low delivery of O<sub>2</sub> to the tissues.

**Stagnant:** low cardiac output, which leads to tissue hypoxia even if the patient is breathing 100% oxygen.

**Anemic:** not enough red blood cells to carry oxygen to the tissues.

**Cytopathic:** the heart pumps enough oxygen to the tissues, but something inhibits effective oxidative phosphorylation (septic shock, cyanide poisoning, salicylate poisoning).

## Hypercarbic Respiratory Failure

Type II, or hypercarbic, respiratory failure is due to an inability of the body to clear CO<sub>2</sub>. Hypoxemia may occur due to hypoventilation, but this is correctable with supplementary oxygen. The best way to determine the cause of hypercarbic respiratory failure is to consider the various ways the body controls CO<sub>2</sub> elimination and look for breakdowns in the system.

Normally, the body is very good at maintaining a normal PaCO<sub>2</sub>. Even during deep sleep, the PaCO<sub>2</sub> varies by 2-3 mm Hg at most. This balance is maintained by the respiratory centers in the medulla oblongata, which stimulate diaphragmatic contractions via the phrenic nerve. When acute hypercarbic respiratory failure occurs, the problem can be localized to either the signaling pathways of the nervous system or the bellows of the respiratory system. Ask yourself —*where is the problem?*

## Localizing the Cause of Hypercapnia

**Brainstem:** drug overdose, trauma, intracerebral or subarachnoid hemorrhage, infection, obesity hypoventilation syndrome, hepatic or uremic encephalopathy, bulbar poliomyelitis?

**Spinal Cord:** lesion at C4 or higher, central cord hematoma, traumatic injury, “high spinal” anesthesia, polio, epidural abscess, transverse myelitis?

**Peripheral Nerves:** phrenic nerve paralysis, tick paralysis, acute inflammatory demyelinating polyneuropathy (Guillain-Barré syndrome), acute intermittent porphyria, heavy metal poisoning?

**Neuromuscular Junction:** botulism, myasthenia gravis, paraneoplastic syndrome, neuromuscular blocking drugs?

**Muscles :** muscular dystrophy, polymyositis, dermatomyositis, hypothyroidism, hypokalemia, hypophosphatemia, hypermagnesemia, steroid-induced myopathy, critical illness polyomyopathy?

**Thoracic Cage:** kyphoscoliosis, thoracoplasty, morbid obesity, flail chest, abdominal compartment syndrome, ankylosing spondylitis, circumferential burn?

**Lungs:** COPD? Dynamic hyperinflation?

## Upper Airway Obstruction

Obstruction of the upper airway can cause respiratory failure. Common causes of upper airway obstruction requiring

acute treatment are trauma, infection (peritonsillar abscess, retropharyngeal abscess), inhaled foreign body, inhalational injury, and angioedema. Stridor is a sign of airflow obstruction at or above the glottis, while expiratory wheezing usually indicates obstruction of the lower airways. Intubation should always be considered, preferably before the patient makes it clear that his airway is completely obstructed.

## **Metabolic Control**

CO<sub>2</sub> is the major byproduct of cellular metabolism. While hypercarbia is most often due to one of the disorders of ventilatory control, occasionally CO<sub>2</sub> production can exceed the capacity of the respiratory system. This can occur during thyroid storm, malignant hyperthermia, cyanide or salicylate poisoning, and with massive catabolism. Ventilatory support may be needed.

Hemodynamic instability and shock can also lead to respiratory failure due to the hypermetabolism seen with sepsis, trauma, and burn injuries. Blood that is directed toward the diaphragm and accessory muscles is shunted away from the splanchnic and hepatic circulation, which can lead to lactic acidosis. Excessive work of breathing can also worsen myocardial ischemia. A worsening metabolic acidosis or cardiac ischemia in the setting of shock are signs of impending respiratory failure and justify mechanical ventilatory support.

A crucial part of managing acute respiratory failure in a patient with a severe metabolic acidosis is to provide enough minute ventilation to compensate for the metabolic process. If a man with ischemic bowel has bicarbonate of 4 and requires intubation, the minute ventilation should be set high enough to obtain a PaCO<sub>2</sub> of 14 mm Hg, the expected amount of respiratory compensation. If the ventilator is set so that the PaCO<sub>2</sub> is in the “normal” range of 35-45, the pH will plummet, and the patient could arrest.

## **Treatment of Acute Respiratory Failure**

The most important thing is to find and treat the underlying cause, if possible. Support can be given to the

patient during the workup and treatment and should not be delayed. Noninvasive support measures include supplemental oxygen and inhaled bronchodilators. Positive pressure ventilation can be given via a noninvasive mask system like CPAP or BiPAP—these are particularly effective for COPD exacerbations with hypercarbia and cardiogenic pulmonary edema. More severe manifestations of respiratory failure like ARDS, multilobar pneumonia, neuromuscular diseases, and cardiogenic shock usually require intubation and mechanical ventilation.

With the exception of reducing the shunt fraction with positive end expiratory pressure, mechanical ventilation is not a therapeutic intervention. The goal of ventilation is to simply maintain adequate gas exchange and metabolic function while the underlying disease process either gets treated or (more commonly) resolves on its own. Thus, the physician should focus on treating reversible causes of respiratory failure and minimizing further injury to the patient. When the patient is ready to come off the ventilator, he'll let you know.

# Chapter 6

## Monitoring the Ventilated Patient

Minute-by-minute monitoring of critically ill patients is a key part of the Intensive Care Unit. As discussed earlier, the respiratory status of a patient can be evaluated with clinical examination, a chest X-ray, and an arterial blood gas. These aren't continually performed, however, and we need tools that allow us to know immediately when there is a change or deterioration in the patient's condition. Pulse oximetry is now used universally to monitor oxygenation. Waveform capnography also can provide some key information and is very helpful, but it is not used on every ventilated patient.

### **Pulse Oximetry**

Pulse oximetry uses two wavelengths of light— red, with a wavelength of 660 nm, and infrared, with a wavelength of 940 nm. Oxygenated hemoglobin preferentially absorbs the infrared light and allows the red light to pass through the tissues; deoxygenated hemoglobin, on the other hand, absorbs red light but not infrared light. When the sensor is placed on a highly vascularized but thin bed of tissue like a fingertip, earlobe, or forehead, the ratio of light absorption can be measured. <sup>3</sup> This is converted to display a reading of the hemoglobin oxygen saturation ( $SpO_2$ ). If the sensor is applied properly and there is adequate perfusion, it is nearly as accurate as the  $SaO_2$  measured with an arterial blood gas analyzer.

Pulse oximetry can be inaccurate if there is hypoperfusion from shock or significant vasoconstriction, either from shock or from vasoconstricting medications like phenylephrine or epinephrine. Generally, an inaccurate  $SpO_2$  reading due to hypoperfusion or vasoconstriction will also have a poor plethysmograph—in other words, the waveform will not be



well-defined, and it will not correlate with the patient's pulse. The SpO<sub>2</sub> also becomes less accurate during significant hypoxemia (SaO<sub>2</sub> < 80%), especially with darkly pigmented skin.

Dyshemoglobinemias can also affect the accuracy of the SpO<sub>2</sub>. Carbon monoxide binds avidly to hemoglobin and absorbs infrared light readily, which leads to a falsely high SpO<sub>2</sub> (98-100%, even with significant arterial hypoxemia). Methemoglobin, on the other hand, affects both infrared and red light absorption and can alter the SpO<sub>2</sub> to underestimate the SaO<sub>2</sub> with lower levels of methemoglobinemia. At higher levels of methemoglobinemia (> 35%), on the other hand, the SpO<sub>2</sub> tends to read 80-85% no matter what the PaO<sub>2</sub> or SaO<sub>2</sub>.

Co-oximetric blood gas analysis is the best way to diagnose dyshemoglobinemias and to see what the true PaO<sub>2</sub> and SaO<sub>2</sub> are. Massimo has developed a noninvasive pulse oximeter that uses additional light wavelengths to accurately display the fraction of oxyhemoglobin, carboxyhemoglobin, and methemoglobin.

There is one situation where the SpO<sub>2</sub> is more accurate than the SaO<sub>2</sub> (the ABG measurement). In hyperleukocytosis due to leukemia (WBC > 50K) or extreme thrombocytosis (platelet count > 1M), activated leukocytes or platelets will continue to consume oxygen in the blood gas syringe before it's placed in the analyzer, leading to falsely low PaO<sub>2</sub> and SaO<sub>2</sub> measurements. Cooling the ABG sample on ice may reduce this, but in general the SpO<sub>2</sub> is more accurate than the SaO<sub>2</sub> when the WBC or platelet count is extremely high.

## **Causes of Inaccurate Pulse Oximetry Measurements**

**Carbon Monoxide Poisoning:** the SpO<sub>2</sub> will read high (98-100%) despite significant arterial hypoxemia.

**Methemoglobinemia:** with significant methemoglobinemia, the SpO<sub>2</sub> will read 80-85% no matter what the SaO<sub>2</sub> or PaO<sub>2</sub> are.

**Vasoconstriction:** can lead to falsely low SpO<sub>2</sub> readings; the waveform is usually poor and not correlated with the patient's

pulse.

**Darkly Pigmented Skin:** can lead to inaccurate SpO<sub>2</sub> readings, but this is rarely seen except when the SpO<sub>2</sub> is < 80%.

## Capnography

Capnometry is the measurement of exhaled carbon dioxide in numerical form, usually measured in mm Hg. Capnography is the same information, but in graphical form. In addition, the capnograph will show the pattern of ventilation. Capnography is becoming a widely accepted practice in the ICU.

Carbon dioxide is the major product of metabolism, and the exhaled CO<sub>2</sub> tension can be used to make assessments of the body's circulatory and ventilatory status. Most (60-70%) carbon dioxide is carried in the bloodstream in the form of bicarbonate ion—carbonic anhydrase in the RBC accounts for this. 20-30% is carried bound to proteins and hemoglobin. This leaves 5-10% to exist as dissolved carbon dioxide, which can be measured as the PaCO<sub>2</sub>. This is the usual measurement of ventilation. The capnograph can provide measurement of the end-tidal CO<sub>2</sub> (E<sub>T</sub> CO<sub>2</sub>), which, when used with the PaCO<sub>2</sub>, can yield a great deal of information.

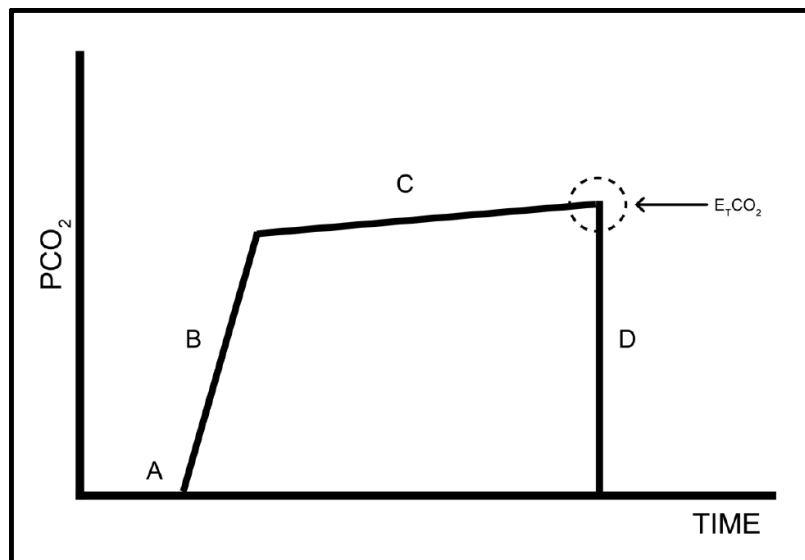

### Breaking Down the Capnograph

A. Respiratory Baseline: This should be at zero. This part of the capnograph indicates the exhalation of

CO<sub>2</sub> -free air—the air in the non-ventilated parts of the tracheobronchial tree. Elevation of the baseline indicates rebreathing of exhaled CO<sub>2</sub> . When the baseline and the E<sub>T</sub> CO<sub>2</sub> rise, this usually means the sensor is contaminated.

- B. Expiratory Upstroke: This should be a steep slope, as it indicates the rapid exhalation of CO<sub>2</sub> from the proximal acini mixed with dead-space gas. When it is less steep, this indicates a prolongation of the time it takes for CO<sub>2</sub> to get from the acini to the sensor. This can be seen in cases of bronchospasm and incomplete obstruction of the endotracheal tube from secretions.
- C. Expiratory Plateau: This should be horizontal, or nearly so. The end point of the plateau is the E<sub>T</sub> CO<sub>2</sub> . This phase indicates the maximal ventilation of CO<sub>2</sub> from the lungs. An up-sloping plateau can represent incomplete alveolar emptying, such as seen in COPD, partial airway obstruction, or obstruction of the endotracheal tube.
- D. Inspiratory Downstroke: The fourth phase represents the inhalation of CO<sub>2</sub> -free gas. Leaks in the ventilator system or cuff can cause prolongation of this phase.

### **Clinical Use of Capnography**

The first step in interpreting the capnograph should be to assess the presence or absence of a waveform. The absence of a waveform indicates one of two things:

1. Failure to ventilate (esophageal intubation, dislodged endotracheal or tracheostomy tube,

obstruction of the tube, apnea). **THIS IS AN EMERGENCY. FIX THE PROBLEM.**

2. Mechanical mishaps—fix the equipment! This should only be considered after you've thoroughly investigated #1, by the way. The CO<sub>2</sub> sensor can get contaminated with mucus secretions, blood, or water and may become faulty. Equipment failure is a diagnosis of exclusion once more serious causes have been ruled out.

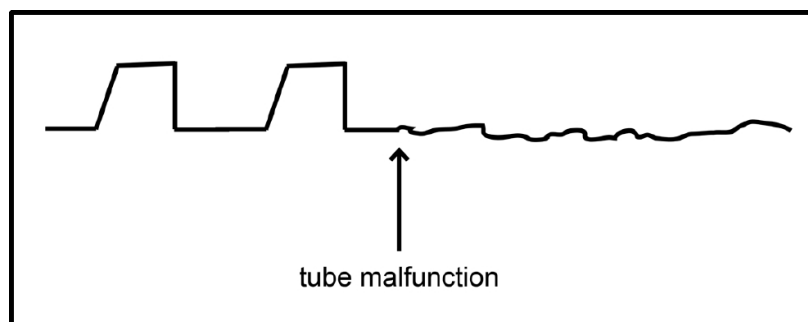

Loss of the capnograph waveform may represent endotracheal or tracheostomy tube dislodgement; tube occlusion; or contamination of the sensor with secretions, etc. In any event, assume that the tube is not functional until that's been ruled out.

Keep in mind that the E<sub>T</sub> CO<sub>2</sub> will never exceed, and rarely match, the PaCO<sub>2</sub>. The E<sub>T</sub> CO<sub>2</sub> isn't a replacement for the arterial blood gas. Knowing that the E<sub>T</sub> CO<sub>2</sub> never exceeds the PaCO<sub>2</sub> is very helpful— it means that whatever the E<sub>T</sub> CO<sub>2</sub>, the PaCO<sub>2</sub> is at least that high. It could be a little higher, or a lot higher, but it's higher.

For example, if a patient has an E<sub>T</sub> CO<sub>2</sub> of 60, you know that the PaCO<sub>2</sub> is at least that. It could be 65, or 105, but it's at least 60. If it's important to the patient to have a PaCO<sub>2</sub> in the 35-40 range, then you know to increase the minute ventilation on the ventilator.

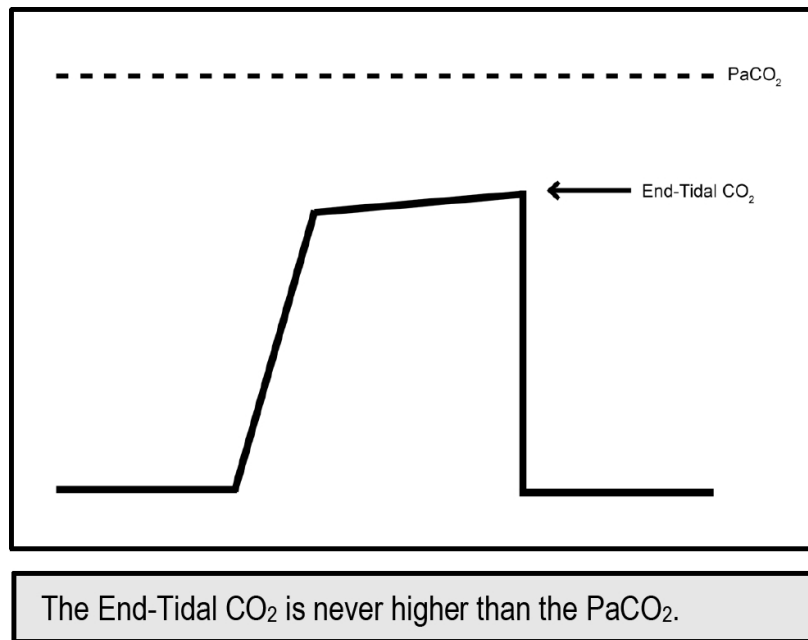

The next step is to compare the  $E_T$  CO<sub>2</sub> with the PaCO<sub>2</sub>. The normal arterial-alveolar CO<sub>2</sub> gradient is usually 3-5 mm Hg. A wide gradient means that there are areas of lung where the ventilation and perfusion aren't matched. Consider the following if there is a large difference between the PaCO<sub>2</sub> and  $E_T$  CO<sub>2</sub>:

1. Poor cardiac function, leading to low perfusion
2. Pulmonary embolism, leading to an increase in dead space
3. ARDS
4. VQ mismatch from COPD, pneumonitis, or other pulmonary pathology
5. Hypovolemia and/or hemorrhage
6. Air trapping from dynamic hyperinflation
7. Overdistension of alveoli from excessive ventilator pressure

It's just as important to follow trends in the gradient. A gradient of 10 mm Hg represents a significant change in a patient who had a PaCO<sub>2</sub> -  $E_T$  CO<sub>2</sub> gradient of 4 mm Hg yesterday.

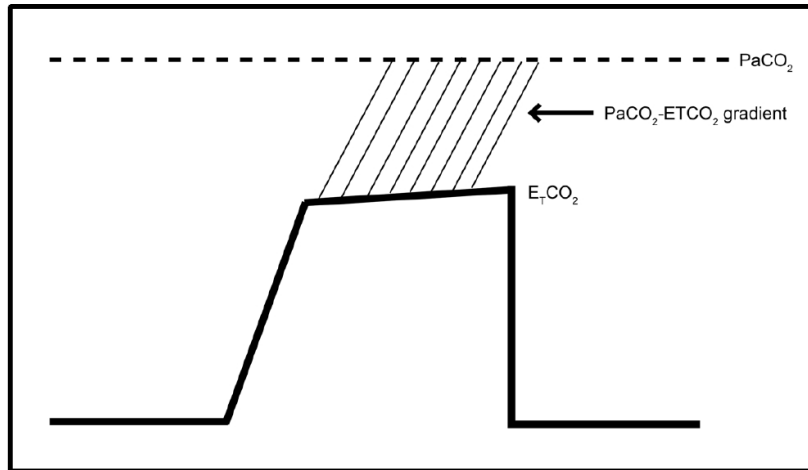

The gradient between the  $\text{PaCO}_2$  and the  $\text{ETCO}_2$  represents the amount of dead space ventilation. The gradient is normally  $< 5$ .

Look at the waveform and its amplitude—a discernable waveform with low amplitude usually represents a sudden increase in dead-space ventilation. However, even cardiac arrest will not drop the plateau to zero—the  $\text{CO}_2$  in the lung must be washed out. A zero or near-zero reading, especially with an abnormal waveform, usually indicates a misplaced ETT, obstruction of the tube, or an equipment problem. A waveform with a gradually decreasing amplitude indicates diminishing  $\text{CO}_2$  production (hypothermia) or decreasing  $\text{CO}_2$  delivery to the lungs (cardiac failure). A sudden increase in the  $\text{E}_T \text{CO}_2$  occurs when there is an abrupt increase in  $\text{CO}_2$  production. This can occur with hyperthermia, after a seizure, bicarbonate administration, reperfusion of an ischemic limb, or ROSC after cardiac arrest.

With severe bronchospasm and other causes of increased airway resistance, there is incomplete emptying of the alveoli during exhalation. This means that the capnograph will not level off as it normally should, and instead it looks more like a shark fin. If you see this, evaluate the patient for high airway resistance.

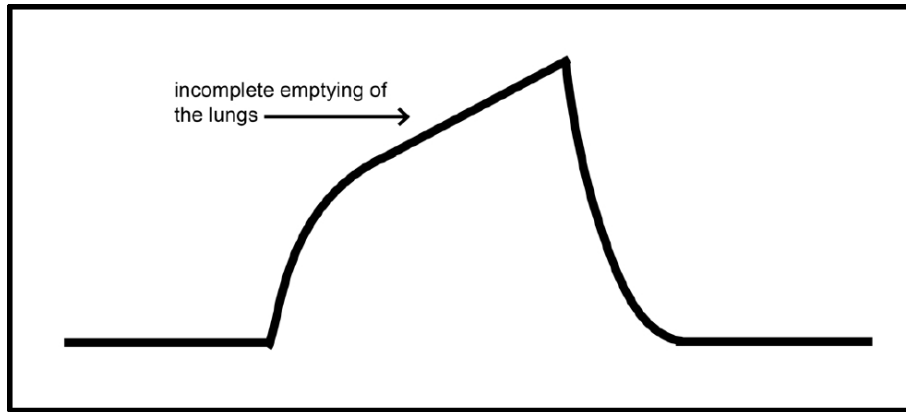

This capnograph has the shark fin appearance seen with bronchospasm. The alveoli aren't able to fully empty, which keeps the capnograph from leveling off.

## Capnography During Cardiopulmonary Resuscitation

CPR is often an unscientific, throw-the-book-at-'em procedure. Capnography is a cheap, noninvasive, objective method for assessing the success or failure of various interventions. Cardiac arrest causes a wide gradient between the arterial and exhaled  $\text{CO}_2$ , due to lack of pulmonary blood flow. Narrowing of the gradient, as demonstrated by rising  $E_T \text{CO}_2$ , indicates increasing pulmonary circulation and therefore increasing cardiac output. Animal and human studies have shown the correlation between  $E_T \text{CO}_2$  and coronary perfusion pressure, the chief predictor of ROSC (return of spontaneous circulation). It also has been shown to correlate with cerebral blood flow.

Transient increases in the  $E_T \text{CO}_2$  can be seen with administration of bicarbonate and high-dose epinephrine. Return of spontaneous circulation will produce a sudden increase in  $E_T \text{CO}_2$ , usually to 40 mm Hg or more.

One major advantage of using capnography in CPR is the ability to assess the efficacy of chest compressions. A drop in the  $E_T \text{CO}_2$  can be due to rescuer fatigue.  $E_T \text{CO}_2$  can also be used to guide the depth and frequency of chest compressions—this is objective data, and much more reliable than pulse

palpation (usually retrograde venous flow). If the  $E_T \text{ CO}_2$  is less than 10 mm Hg, the American Heart Association's ACLS Guidelines suggest trying to improve CPR quality by optimizing chest compressions. Additionally, a discernable waveform and  $E_T \text{ CO}_2$  may reflect pseudo-electromechanical dissociation, which should be treated with vasopressors and fluid support.

## **Interpretation of Changes in $E_T \text{ CO}_2$**

### **Rising $E_T \text{ CO}_2$ , Rising $\text{PaCO}_2$ :**

Alveolar hypoventilation due to oversedation, diminished respiratory drive, or neuromuscular weakness.

Increased  $\text{CO}_2$  production from hyperthermia, thyrotoxicosis, reperfusion, ROSC following cardiac arrest, etc.

### **Falling $E_T \text{ CO}_2$ , Falling $\text{PaCO}_2$ :**

Alveolar hyperventilation due to pain, agitation, fever, etc.

### **Falling $E_T \text{ CO}_2$ , Unchanged or Rising $\text{PaCO}_2$ :**

Increased pulmonary dead space due to pulmonary embolism, worsening cardiac function, bleeding, hypovolemia, or dynamic hyperinflation with autoPEEP.



# Chapter 7

## Arterial Blood Gas Analysis for the Compleat Idiot

Or,

**How to impress your attendings and become the envy of your peers by making difficult concepts seem easy (which they really are)!**

Few things are as troublesome for residents and medical students as dealing with complex acid-base disorders. Medical textbooks are usually not helpful, because they devote pages and pages to logarithmic curves, “K” factors, physiochemical properties of solutions, and the dreaded Henderson-Hasselbach equation.

The first thing you need to do to solve acid-base problems is to RELAX. It’s really not that hard! Don’t worry if you didn’t do well on the Renal test in Physiology. Even if you punted the acid-base section of Biochemistry, it doesn’t matter. You don’t need to studiously cram every  $K'_a$ , logarithm, and complex equation into your brain! You have more important things to learn. Clinical acid-base problem solving only requires a basic understanding of physiology, a few simple equations, and a step-by-step approach. The most important thing to have is a good history and physical and a dollop of common sense.

There are many different methods for approaching acid-base problems, and this is by no means authoritative; each person should adopt a method he can understand and use easily. One great read is the book Acid-Base, Fluids, and Electrolytes Made Ridiculously Simple.

The most important thing to remember when dealing with acid-base problems is to put everything in the clinical context of the patient at hand! Solving these problems in a vacuum ignores the whole reason you obtained the ABG to begin with. If the ABG analysis seems to go along with what you

clinically suspect, great! If it is wildly off, you should think of two things—lab error or misdiagnosis.

The following method consists of three parts. It is important to address all three parts every time you attempt to solve a problem.

### **Step One: Determine the Primary Disorder**

Determine the primary disorder. This requires an arterial blood gas sample. Look at the pH first. Normal pH is 7.35 to 7.45, with a dividing line at 7.40. If the pH is less than 7.35, the patient is acidemic; that is, the net charge of his bloodstream is acidic. Next, look at the PaCO<sub>2</sub>. If the PaCO<sub>2</sub> is less than 40 (and usually less than 35), the problem is a metabolic acidosis. The patient is hyperventilating to rid himself of acidic carbon dioxide. If the PaCO<sub>2</sub> is greater than 40 (usually 45), the primary disorder is a respiratory acidosis. Retention of CO<sub>2</sub> is making the patient acidemic.

If the patient is alkalemic (his pH is greater than 7.45), a low PaCO<sub>2</sub> (less than 35) means that the primary disorder is a respiratory alkalosis. If the PaCO<sub>2</sub> is greater than 45, the primary disorder is a metabolic alkalosis and the patient is hypoventilating to control his pH.

Remember—the human body rarely, if ever, can compensate back to a normal range! That brings us to Step Two....

### **Step Two: Check for Compensation**

Is the compensation adequate? When the primary disorder is metabolic, the patient will either hyper- or hypoventilate to try to maintain homeostasis. This is called respiratory compensation. Your next step is to determine if this compensation is adequate. If it's not, there is another disorder besides the primary one. The compensation formulas require the PaCO<sub>2</sub> and the serum HCO<sub>3</sub><sup>-</sup>. If the HCO<sub>3</sub><sup>-</sup> on the serum metabolic panel and the ABG are different, go with the serum panel. It's measured, while the value on the ABG is calculated. Normal HCO<sub>3</sub><sup>-</sup> should be 24.

---

**Compensation for Metabolic Acidosis:**

$$\text{Expected PaCO}_2 = (1.5 \times \text{HCO}_3) + 8$$

For instance, if the pH is 7.22, the PaCO<sub>2</sub> is 27, and the HCO<sub>3</sub> is 14, we know that the primary problem is a metabolic acidosis (low pH, low PaCO<sub>2</sub>). According to our compensation formula, the expected PaCO<sub>2</sub> is 29 (1.5 x 14) + 8 = 29]. Give yourself a “fudge factor” of about 2 on either side of the predicted value. Our conclusion—this patient has a metabolic acidosis with appropriate respiratory compensation. Try not to say that he has a “compensatory respiratory alkalosis.” Alkalosis implies a pathologic process. In this case, the compensation is a perfectly normal response to acidosis.

Another example: A patient has a pH of 7.12, a PaCO<sub>2</sub> of 32, and a HCO<sub>3</sub> of 10. Again, the primary disorder is a metabolic acidosis. The expected PaCO<sub>2</sub>, however, is 23 by the formula, and the patient’s PaCO<sub>2</sub> is 32. This is higher than expected and suggests a coexistent respiratory acidosis. The diagnosis? A combined respiratory and metabolic acidosis. Is this a drug overdose? A septic patient with respiratory failure? Again, correlate clinically!

One more: pH 7.32, PaCO<sub>2</sub> 24, HCO<sub>3</sub> 16. Primary disorder—metabolic acidosis. Expected PaCO<sub>2</sub> —32. The PaCO<sub>2</sub> is lower than you expect, so this patient has a metabolic acidosis with a coexisting respiratory alkalosis.

**Compensation for Metabolic Alkalosis:**

$$\text{Expected PaCO}_2 = (0.7 \times \text{HCO}_3) + 21$$

Metabolic alkalosis is most often due to volume depletion, especially as a result of vomiting or NG suctioning. Hyperaldosteronism and other types of mineralocorticoid excess are other, albeit rare, causes. An example: pH 7.52, PaCO<sub>2</sub> 42, HCO<sub>3</sub> 30. This is a metabolic alkalosis, and the expected PaCO<sub>2</sub> is 42— this patient has a metabolic alkalosis with appropriate respiratory compensation. This could be a patient with pancreatitis who has been vomiting for three days.

What if the pH were 7.53, the  $\text{HCO}_3$  40, and the  $\text{PaCO}_2$  60 (a CHF patient who received a 50cc bolus of sodium bicarbonate)? This is a metabolic alkalosis, but the expected  $\text{PaCO}_2$  is 49. This patient has a metabolic alkalosis and a coexisting respiratory acidosis .

With respiratory disorders, you have to determine if the process is acute or chronic. Generally speaking, chronic disorders have been present for 3-5 days or more, giving the kidneys time to equilibrate. Patients with chronic respiratory acidosis (emphysematous “ $\text{CO}_2$  retainers”) usually have a near-normal pH despite high  $\text{PaCO}_2$  levels; clinically, they can tolerate higher levels of  $\text{PaCO}_2$  without becoming obtunded. The compensation formulas are:

**Compensation for Respiratory Acidosis:**

Acute:

$\text{HCO}_3$  rises 1 for every 10 the  $\text{PaCO}_2$  rises

Chronic:

$\text{HCO}_3$  rises 3-4 for every 10 the  $\text{PaCO}_2$  rises

For instance, if a patient with emphysema has a pH of 7.34, a  $\text{PaCO}_2$  of 60, and a  $\text{HCO}_3$  of 32, he has a chronic respiratory acidosis with appropriate metabolic compensation . Clues to the chronic nature of his disease are the history (COPD), the higher  $\text{HCO}_3$  , and the near-normal pH. This patient is also speaking easily; someone who was previously normal would be stuporous or comatose with a  $\text{PaCO}_2$  of 60.

Another case: A patient who received too much morphine is now stuporous. His ABG shows a pH of 7.26, a  $\text{PaCO}_2$  of 55, and a  $\text{HCO}_3$  of 27. He has a respiratory acidosis, and his expected  $\text{HCO}_3$  is 26. Therefore, he has an acute respiratory acidosis with appropriate metabolic compensation .

Finally, consider an unconscious patient brought in from a house fire. His pH is 7.13, his  $\text{PaCO}_2$  is 60, and his  $\text{HCO}_3$  is 16. His primary problem is respiratory (you could call it metabolic and work it up from that angle—dealer’s choice),

and his expected  $\text{HCO}_3$  is 26, which is higher than the measured  $\text{HCO}_3$ . He has a combined respiratory and metabolic acidosis. In this case, cyanide is the culprit.

In respiratory alkalosis, the same rules about acute and chronic conditions apply. Chronic respiratory alkalosis is usually due to pregnancy, chronic hypoxemia, chronic liver disease, and medication side effects.

**Compensation for Respiratory Alkalosis:**

Acute:

$\text{HCO}_3$  drops 2 for every 10 the  $\text{PaCO}_2$  falls

Chronic:

$\text{HCO}_3$  drops 5 for every 10 the  $\text{PaCO}_2$  falls

An example: A patient is brought in after sudden onset of dyspnea and tachypnea (30-34 breaths per minute). Her pH is 7.52, her  $\text{PaCO}_2$  is 25, and her  $\text{HCO}_3$  is 21. The expected  $\text{HCO}_3$  is therefore 21 (by the above formula), so she has an acute respiratory alkalosis with appropriate metabolic compensation. CT scan shows a pulmonary embolism.

After you see that patient, you are asked to see an elderly lady who has been vomiting for two days. History reveals that she has accidentally been taking her theophylline three times a day instead of twice, and her theophylline level is 30 (toxic). Her ABG shows a pH of 7.58, a  $\text{PaCO}_2$  of 30, and a  $\text{HCO}_3$  of 29. She has a chronic respiratory alkalosis (a known side effect of theophylline, especially high doses) as well as a metabolic alkalosis from vomiting.

What about all of those formulas? Sorry, there are no shortcuts in Step Two. Either write them down in a notepad or memorize them. The more tech-savvy will keep them readily available on a smartphone. As you become more of an aficionado, the formulas will come to you easily.

### Step Three: Mind the Gap

You'll remember that there are two types of metabolic acidosis—those that cause an anion gap, and those that don't. The anion gap, if you recall, is calculated as  $[\text{Na} - (\text{Cl} + \text{HCO}_3)$

)]. The normal value is around 12, and accounts for unmeasured anions like plasma proteins. If the calculated gap is at least 3-4 higher than normal, consider it elevated. Hypoalbuminemia can falsely lower the anion gap, so the normal value should be the serum albumin multiplied by 3. Step Three of the method requires you to calculate the anion gap and create a differential diagnosis based on it. The differential can be remembered by the following mnemonics. Don't worry—remembering how to spell 'mnemonic' is harder than solving acid-base problems!

### **A Few Causes of an Elevated Anion Gap**

#### **Acidosis**

#### **(MUDPILES)**

**M** ethanol poisoning  
**U** remia  
**D** iabetic ketoacidosis  
**P** araldehyde poisoning  
**I** ron, **I** soniazide poisoning  
**L** actic acidosis  
**E** thylene glycol poisoning, **E** thanol  
ketoacidosis  
**S** alicylate poisoning, **S** tarvation  
ketoacidosis, **S** epsis

### **A Few Causes of a Non-Anion Gap Acidosis**

#### **(HARD UP)**

**H** yperchloremia (saline, TPN)  
**A** ddison's disease, **A** cetazolamide  
**R** enal tubular acidosis  
**D** iarrhea  
**U** reteral diversion procedures  
**P** ancreatic problems (pseudocyst, fistula)

The presence or absence of an anion gap will help you determine the cause of a metabolic acidosis. Sometimes, it is the only clue that a metabolic acidosis exists. In addition, the rise in the anion gap above normal should correlate with the

drop in  $\text{HCO}_3^-$  from the normal value (24). If the  $\text{HCO}_3^-$  is higher than expected, there is a coexisting metabolic alkalosis. If the  $\text{HCO}_3^-$  is lower than expected, there may be a coexisting non-anion gap acidosis present.

Here's a case: A 23-year-old diabetic comes to the hospital in shock. His parents say that he has been vomiting constantly for 4 days. Your colleague asks you to help him decipher the patient's blood gas and chemistry. His blood glucose is 399, his serum Na is 133, the Cl is 90, and the  $\text{HCO}_3^-$  is 20. His pH is 7.20 and the  $\text{PaCO}_2$  is 40. What's going on?

1. The primary disorder is a metabolic acidosis, probably DKA (confirmed by elevated serum acetone).
2. The expected  $\text{PaCO}_2$  should be 38, and his is 40—therefore, he has a metabolic acidosis with appropriate respiratory compensation.
3. His anion gap is 23—elevated, consistent with DKA. But wait! The rise in the anion gap is 11 (23-12), so his  $\text{HCO}_3^-$  should have dropped by around 11 to give us a serum bicarbonate of 13 (24-11). His  $\text{HCO}_3^-$  is 20, which is significantly higher than expected. This suggests a coexisting metabolic alkalosis, brought about by his vomiting and dehydration. The final word? This patient has diabetic ketoacidosis with a concomitant metabolic alkalosis due to volume depletion.

In closing....

Hopefully, this guide will help you sort out the confusing acid-base problems you will come across in clinical practice. Remember that practice makes perfect—go through every step on every ABG you come across. You don't need to tell anyone how easy it is—in fact, you can mutter some things about “logarithmic changes” and “titratable acidity in the setting of the Isohydric Principle” while you easily solve the problem, if you want to make it look as hard as everyone else seems to think it is. In time, you'll be known as a Guru of the Gas.

# Chapter 8

## Assist-Control Ventilation

Assist-control (A/C) ventilation is the mode that requires the least effort from the patient. The ventilator will deliver a preset number of breaths per minute, no matter what—this is the “control” part. If the patient wants to breathe more frequently than the set rate, he can (the “assist” part). When he triggers the ventilator, the machine will deliver a full breath. In other words, all the patient has to do is open the demand valve to let the ventilator’s computer know that he wants a breath, and the vent does the rest.

So, if the ventilator is programmed to give 12 breaths a minute, then the patient will receive 12 breaths per minute even if he makes no effort at all. If he wants to breathe over the vent, all he has to do is generate the minimum flow or pressure needed to trigger the vent. This effectively takes over the work of breathing and is very useful for situations where the patient is unable to meet his own respiratory needs—e.g. shock, acute respiratory distress syndrome (ARDS), pulmonary edema, multisystem trauma, etc.

### **Compliance**

In order to understand positive pressure ventilation, it’s important to understand the concept of respiratory system compliance. Compliance can be expressed mathematically as the ratio between the change in volume and the change in pressure.

The compliance of the respiratory system depends on the individual compliance of its two components—the lungs and the chest wall. The normal compliance of each of these is around 200 mL/cm H<sub>2</sub> O. Since it’s very difficult in clinical practice to isolate the two (at least in living patients), we need to consider the two components working together in a parallel



circuit. Remember that the reciprocal of the total resistance of a parallel circuit is the sum of the reciprocals of the resistance of each component. So,

$$1/C_{RS} = 1/C_L + 1/C_{CW}$$

Plugging in the normal compliance of the lungs and chest wall,

$$1/C_{RS} = 1/200 + 1/200 = 2/200 = 1/100$$

Therefore, the compliance of the normal respiratory system is 100 mL/cm H<sub>2</sub>O. Application of 5 cm H<sub>2</sub>O pressure via mask or an endotracheal tube should increase the volume of normal lungs by 500 mL. Any disease process that reduces the compliance of the lungs (pneumonia, atelectasis, pulmonary fibrosis, pulmonary edema, pneumothorax) will reduce the compliance of the respiratory system as a whole. Likewise, a reduction in the compliance of the chest wall (subcutaneous edema, circumferential burn, elevated intraabdominal pressure) will reduce respiratory system compliance.

With positive pressure ventilation, a certain amount of pressure is applied to the lungs by the ventilator to generate a volume, known as the tidal volume. The amount of pressure needed to get the tidal volume depends on the respiratory system compliance. The physician will decide which of these (pressure or volume) is the dependent variable and which is the independent variable.

If you choose to make the tidal volume the independent variable, then the mode is known as volume assist-control, or volume control. The tidal volume will be set, and the ventilator will provide as much pressure as it takes to reach the desired volume. If the compliance is poor, then it will take a higher amount of pressure. If the patient's compliance improves, then it will take less pressure to deliver the target volume.

You can also choose to set the driving pressure—the change in pressure over the course of the delivered breath. Now, the tidal volume depends on the compliance and may

vary as the compliance improves or worsens. This is known as pressure assist-control, or pressure control, ventilation.

Many people argue over the merits and drawbacks of volume control and pressure control ventilation. Each side has its adherents, but the fact remains that the two are linked by the compliance equation. The only difference is in what variable the physician chooses to control. So, much of this argument is ado about nothing. The ventilator can't give a tidal volume without positive pressure, and it can't deliver a driving pressure without generating a tidal volume.

## Setting the Tidal Volume

For many years, physicians believed that ventilator-induced lung injury (VILI) was primarily due to excessive airway pressures. At the same time, higher tidal volumes were used to keep the PaCO<sub>2</sub> in the normal range and to prevent atelectasis. Over the last two decades, however, research has shown that the major factor behind VILI is volutrauma, or overdistension of alveoli. The landmark ARDSNET study [4](#) demonstrated that by using a tidal volume of 4-6 mL/kg (compared with 12 mL/kg), mortality in patients with the acute respiratory distress syndrome (ARDS) or acute lung injury (ALI) was reduced by 9%. If you don't think this is a big deal, think again—since ARDS was first described in 1967, this was the first thing that was shown to improve survival!

Some have criticized the ARDSNET study for using too high of a tidal volume in the control group. However, this was probably closer to routine practice than you might think. Tidal volume should be based on predicted body weight (PBW), not actual body weight. If a man gains 200 pounds, his lungs don't get any bigger. PBW can be calculated if you know the patient's height and gender.

## Calculating Predicted Body Weight

**Men:**

$$\text{PBW (kg)} = 0.91 \times [\text{Height in cm} - 152.4] + 50$$

**Women:**

$$\text{PBW (kg)} = 0.91 \times [\text{Height in cm} - 152.4] + 45.5$$

In general, the initial tidal volume should be set at 6-8 mL/kg PBW. If the patient has ARDS, then a tidal volume of 4-6 mL/kg is more appropriate. People with obstructive airway disease often need a slightly higher tidal volume (7-8 mL/kg) to prevent air trapping. There is some evidence that tidal volumes above 8 mL/kg may cause VILI even in people with healthy lungs, so exceeding this volume is not advisable. [5](#)

## Tidal Volume Chart—Females

Height (ft/in)	4 mL/kg PBW	6 mL/kg PBW	8 mL/kg PBW
5' 0	182	273	364
5' 1	191	287	382
5' 2	200	301	401
5' 3	210	314	419
5' 4	219	328	438
5' 5	228	342	456
5' 6	237	356	474
5' 7	246	370	493
5' 8	256	383	511
5' 9	265	397	530
5' 10	274	411	548
5' 11	283	425	566
6' 0	292	439	585
6' 1	302	452	603
6' 2	311	466	622
6' 3	320	480	640
6' 4	329	494	658
6' 5	338	508	677
6' 6	348	521	695
6' 7	357	535	714
6' 8	366	549	732
6' 9	375	563	750
6' 10	384	577	769
6' 11	394	590	787
7' 0	403	604	806

## Tidal Volume Chart—Males

Height (ft/in)	4 mL/kg PBW	6 mL/kg PBW	8 mL/kg PBW
5' 0	200	300	400
5' 1	209	314	418
5' 2	218	328	437
5' 3	228	341	455
5' 4	237	355	474
5' 5	246	369	492
5' 6	255	383	510
5' 7	264	397	529
5' 8	274	410	547
5' 9	283	424	566
5' 10	292	438	584
5' 11	301	452	602
6' 0	310	466	621
6' 1	320	479	639
6' 2	329	493	658
6' 3	338	507	676
6' 4	347	521	694
6' 5	356	535	713
6' 6	366	548	731
6' 7	375	562	750
6' 8	384	576	768
6' 9	393	590	786
6' 10	402	604	805
6' 11	412	617	823
7' 0	421	631	842

**Check the Alveolar Pressure**

Once the tidal volume is determined, check the distending pressure on the alveoli. This is known as the plateau pressure and can be observed by putting an end-inspiratory pause of 0.5-1 seconds on the ventilator circuit (most vents have a button designed for this purpose). When an end-inspiratory pause occurs, flow stops. You can demonstrate this on yourself by taking in a breath and then holding it for one second. At this point, pressure will equilibrate across the system, and the pressure in the endotracheal tube will equal the pressure in the alveoli.

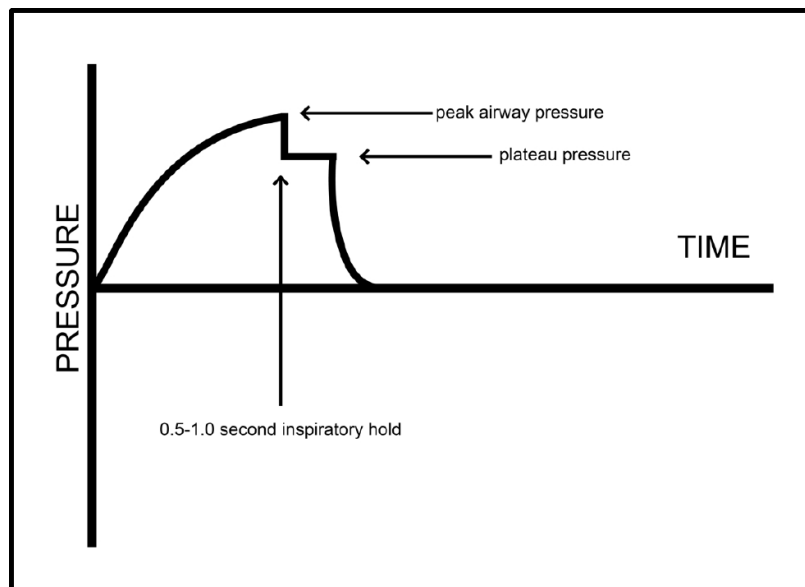

The plateau pressure, or  $P_{PLAT}$ , represents the equilibration of pressures throughout the lungs when flow is stopped. This is the best assessment of the alveolar pressure.

The normally quoted safe plateau pressure is 30-35 cm H<sub>2</sub>O. If you ask healthy volunteers to breathe in to total lung capacity, the maximal transpulmonary pressure generated is 30-35 cm H<sub>2</sub>O. This is where this number comes from. However, no one actually knows what the true “safe” plateau pressure really is, or if it even exists. Studies of patients with ARDS show that the lower the plateau pressure, the better the survival; however, this may be simply due to correlation with no causal relationship.<sup>4</sup> Secondly, the primary mechanism behind VILI is volutrauma,<sup>6</sup> which occurs independently of barotrauma. Therefore, it makes sense to not exceed plateau pressures of 35 cm H<sub>2</sub>O. At the same time, using higher than

recommended tidal volumes cannot be considered safe even if the plateau pressure is less than 30. If the plateau pressure exceeds 35, lower the tidal volume (to 4 mL/kg, if necessary). Since excessive tidal volumes can be dangerous, changing the rate should be the primary way to adjust the minute ventilation.

## Volume Assist-Control

Volume assist-control ventilation (VCV) requires the physician to set a rate and a tidal volume. The product of these two numbers is known as the minute ventilation, and it is the minute ventilation that determines how much carbon dioxide is eliminated from the body. Normal minute ventilation for a healthy person at rest is between 4 and 5 liters per minute, but this can increase with fever, infection, metabolic stress, and exercise. Increasing the ventilator rate or tidal volume will increase the minute ventilation and will blow off more  $\text{CO}_2$ . Lowering the minute ventilation (by decreasing the ventilator rate or the tidal volume) will permit the arterial  $\text{CO}_2$  tension to rise. If the patient wants to breathe over the set rate, he can. Every time he triggers the vent, he will receive the full set tidal volume.

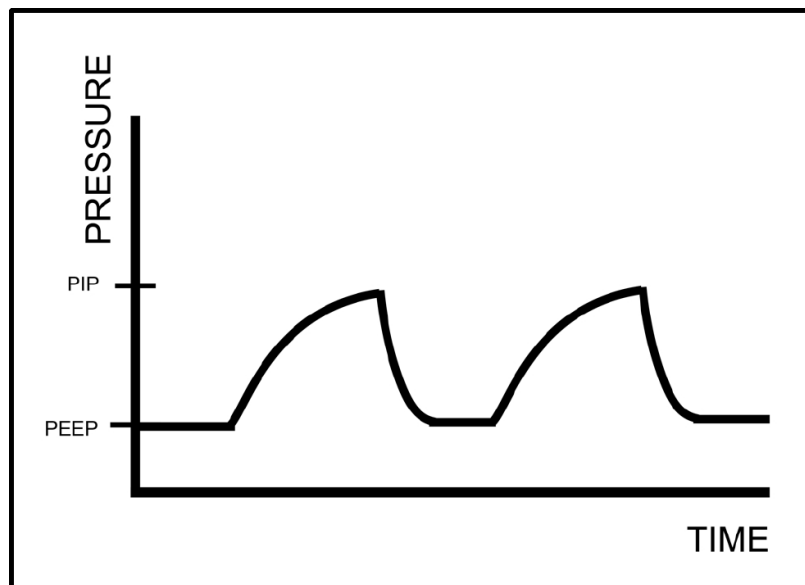

In volume-control ventilation, the ventilator will increase the airway pressure until the goal tidal volume is reached.

VCV delivers a constant flow of gas during inspiration until the target tidal volume is reached. The waveform on the ventilator is referred to as a “square top” inspiratory flow.

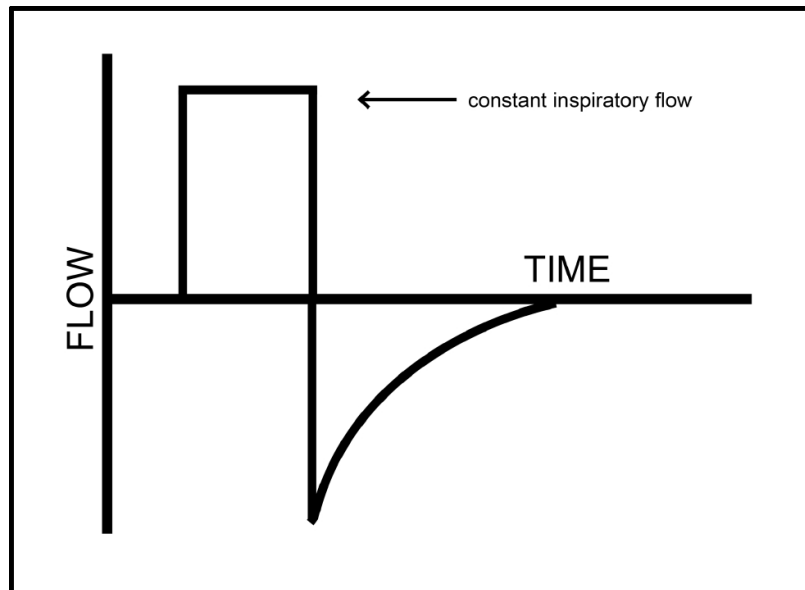

In volume-control ventilation, the ventilator will deliver a constant flow of gas until the goal tidal volume is reached, then turn off the gas. Exhalation is passive.

Patients with COPD or asthma often like this— they typically have a high degree of air hunger and getting the tidal volume in quickly helps alleviate it. Other patients, however, find constant inspiratory flow to be uncomfortable, like drinking from a fire hose. Modern ventilators may permit the clinician to select a decelerating flow instead, which usually improves patient comfort. This is discussed in more detail in the chapter on “Trigger and Flow.”

## **Pressure Assist-Control**

In pressure assist-control ventilation (PCV), the physician sets a rate and a driving pressure. This is the change in pressure that occurs during either a machine-administered or patient-triggered breath (remember, in assist-control the patient can breathe above the set rate). In addition, an inspiratory time (I-time) must be selected. In VCV, the ventilator turns off the flow once the target tidal volume has been reached. In PCV, the ventilator goes up to a set pressure



and will hold it as long as it's told before it turns off the flow—this is the I-time.

The ratio between the I-time and the expiratory time is known as the I:E ratio. In spontaneously breathing people, this ratio is usually between 1:2 and 1:4. In other words, breathing in takes about one second, and between two and four seconds is spent exhaling. When setting the ventilator, pay attention to the total time for each breath. If the rate is 20 breaths per minute, then it's 3 seconds per breath (60 seconds divided by 20). If the I-time is one second, then the expiratory time is two seconds—hence, a 1:2 ratio. If the rate is 15 breaths per minute and the I-time is one second, then the I:E ratio is 1:3 (60 seconds divided by 15 breaths is 4 seconds per breath).

Once the I:E ratio is 1:1 or higher, it's known as inverse-ratio ventilation. If the vent rate is 20 and the I-time is set at 2 seconds, then the I:E ratio is 2:1. Try breathing in for two seconds and then out for one—this is uncomfortable. There are special situations where inverse ratio ventilation is useful (such as severe ARDS), but it requires a great deal of sedation. In general, keep the I:E ratio between 1:2 and 1:4.

The driving pressure is the pressure change during the breath. What this means is that when it's time for a breath, the pressure rises from whatever it is at end-expiration to a peak pressure, holds for the I-time, and then goes back to the end-expiratory pressure. For example: a patient has a set rate of 15, a driving pressure of 20 cm, an I-time of 1.0 seconds, and a positive end-expiratory pressure (PEEP) of 10 cm. 15 times a minute, the pressure will rise from the PEEP of 10 to a peak pressure of 30 cm (peak – PEEP = driving pressure). The pressure will hold at 30 cm for one second and then return to 10 cm, the PEEP.

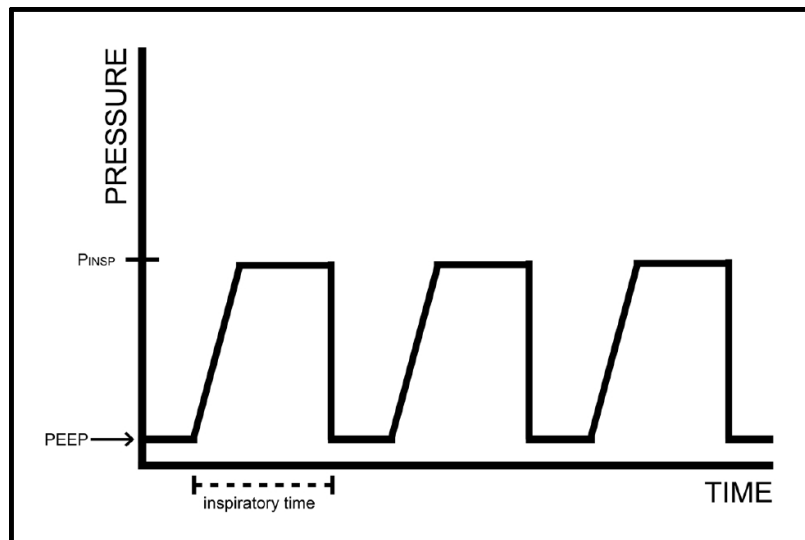

In pressure-control ventilation, the ventilator will go up to the inspiratory pressure and hold it for the selected inspiratory time, then terminate the breath. The tidal volume generated depends on the compliance of the respiratory system.

The tidal volume generated by the driving pressure depends on the patient's respiratory system compliance. If the compliance is poor, say 15 mL/cm H<sub>2</sub>O, then a driving pressure of 20 cm will yield a tidal volume of 300 mL. If the compliance improves to 30 mL/cm H<sub>2</sub>O, then the tidal volume will also double to 600 mL. In critically ill patients, compliance can change rather quickly and result in erratic tidal volumes. Some physicians consider the lack of a reliable, guaranteed tidal volume to be a drawback of PCV. Others see this as a strength, with the rationale that tidal volumes are not usually consistent in spontaneous breathing. Whether this is a bug or a feature is not settled.

In general, the driving pressure should be set at whatever pressure generates a tidal volume of 6-8 mL/kg PBW, or 4-6 mL/kg if the patient has ARDS. As the patient's compliance improves, you will need to lower the driving pressure to keep the tidal volume in this range. Even though the independent variable is pressure and not volume, don't ignore the potential for volutrauma. The peak airway pressure (driving pressure + PEEP) should not exceed 30-35 cm H<sub>2</sub>O if at all possible.

An analysis of ARDS patients published in 2015 concluded that the driving pressure was the factor most

associated with survival, even more so than the tidal volume or PEEP. <sup>7</sup> A threshold of 15 cm was identified as being independently related to survival, even when the plateau pressure was kept at 30 cm H<sub>2</sub>O or less and the tidal volume was 7 mL/kg or lower. Other studies have supported this conclusion.

The driving pressure indexes the tidal volume to the compliance of the respiratory system—it's just the compliance equation written another way.

$$\begin{aligned} \text{Compliance} &= \Delta\text{Volume} / \Delta\text{Pressure} \\ C_{\text{RS}} &= \text{Tidal Volume} / \text{Driving Pressure} \\ \text{Driving Pressure} &= \text{Tidal Volume} / C_{\text{RS}} \end{aligned}$$

It stands to reason that a patient with more severe ARDS will have reduced compliance, which means that it will take more pressure to get a given tidal volume. In less severe cases, the driving pressure needed to get a tidal volume of 6 mL/kg will be lower (due to better respiratory system compliance). This suggests that the driving pressure may be more of a reflection of disease severity.

The literature related to the driving pressure in ARDS is also retrospective and *post hoc* analysis. At the time of this writing, there are no prospective studies directly comparing a driving pressure-guided ventilation strategy with a low tidal volume-based approach. Therefore, taking the stance that the tidal volume is irrelevant so long as the driving pressure is less than 15 is not supported by medical evidence. It would be more prudent to see the driving pressure as a speed limit of sorts—if it takes more than 15 cm pressure to get a tidal volume of 6 mL/kg, consider lowering the targeted tidal volume.

PCV breaths are delivered with decelerating inspiratory flow. Because the ventilator simply goes up to the inspiratory pressure and holds it, flow of gas will naturally slow as the lungs fill. This is considered to be more comfortable than a constant, or square-top, inspiratory flow.

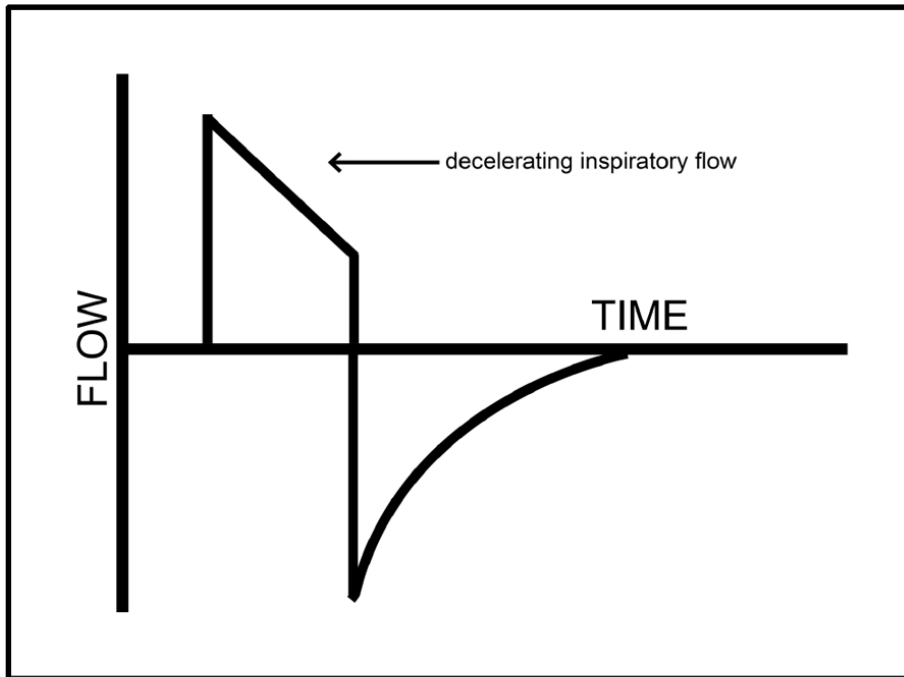

In pressure-control and dual-control ventilation, the flow of gas is initially high. As the lungs fill, the flow of gas slows down, or decelerates. The breath is terminated by either the end of the inspiratory time (PCV) or when the goal tidal volume is reached (PRVC and other dual-control modes). Exhalation is passive.

## Dual-Control Modes

What if you could have the best of both worlds? The ability to set the tidal volume, like with volume-control, but with the comfort of decelerating inspiratory flow that pressure-control has? Have no fear—the ventilator companies have heard your requests and have developed so-called “dual control” modes of ventilation. These are known by different trademarked terms—PRVC<sup>™</sup> (pressure-regulated volume control) by Maquet; CMV with Autoflow<sup>™</sup> by Dräger; and VC+<sup>™</sup> by Puritan-Bennett, to name a few. All of these do essentially the same thing, which is to deliver a volume-targeted breath with decelerating flow.

Dual-control modes ask the clinician to enter a tidal volume, a rate, and an inspiratory time. With this data, the ventilator will give the patient the tidal volume over the preset inspiratory time, adjusting the flow throughout the inspiratory

cycle to get the volume in with the lowest pressure possible. The ventilator can also sense the patient's own inspiratory efforts and will adjust the flow accordingly to improve comfort.

The actual delivery of the gas is like pressure-control ventilation. In fact, if you were to look at a pressure-time and flow-time waveform for a dual-control mode, it would look the exact same as in PCV. That's because it essentially is the same thing. Imagine telling the ventilator that you want the patient to be in PCV, but the ventilator can adjust the driving pressure up or down as needed to reach a predefined tidal volume. That's what's happening here. As the patient's compliance changes, the inspiratory pressure will also change in order to keep the tidal volume where the clinician sets it. PRVC, CMV with Autoflow, and VC+ are pressure-control modes for people who don't like pressure-control.

So why haven't these dual-control modes completely replaced VCV and PCV? Most of the time, they have. Dual-control ventilation is popular because it lets the clinician control the tidal volume while delivering the volume in a more comfortable way. The peak pressures are lower than in VCV and most of the time it works very well. What's the downside?

Keep in mind that dual-control ventilation adjusts the inspiratory pressure to reach the desired tidal volume and makes changes on a breath-by-breath basis. If a patient is making spontaneous respiratory efforts, he can breathe over the vent like in all assist-control modes. If he's got a strong respiratory drive or a lot of air hunger, however, it can lead to significant patient-ventilator dyssynchrony.

Let's say that the tidal volume is set for 500 mL, and the ventilator initially has the inspiratory pressure at 20 cm. The patient pulls in a few big breaths of 800-900 mL. The ventilator's computer interprets this as an improvement in compliance— hey, the guy's getting better! —and lowers the inspiratory pressure to 10 cm. That's not enough, and the patient reacts by taking a few quick breaths of 150-200 mL. The ventilator then ramps the pressure back up, doing its best to keep the tidal volume around 500 mL. This yo-yoing

pressure and tidal volume is certainly not comfortable and leads to further dyssynchrony. To the clinician, it may appear that the patient is “fighting” the ventilator and suggests the need for heavier sedation. What actually needs to happen is for the ventilator to be changed to deliver either a set tidal volume (VCV) or a set inspiratory pressure (PCV). Dual-control modes are adaptive— that’s their strength—but sometimes that adaptiveness is counterproductive.

# Chapter 9

## Synchronized Intermittent Mandatory Ventilation

Intermittent mandatory ventilation (IMV) was introduced in the 1970s as an alternative to assist-control ventilation. Like assist-control, the ventilator is set to deliver a predetermined number of breaths per minute. Later, the mode was improved by synchronizing the preset ventilator breaths with the patient's spontaneous breathing—if the machine detects that the patient is breathing, it will delay the machine breath to prevent a machine-given breath from occurring while the patient is exhaling. This synchronization is what puts the S in SIMV.

Most commonly, the machine-delivered breaths are volume-controlled (e.g., the physician sets a tidal volume). This is not the only option, though—many ventilators will allow the IMV breath to be pressure-controlled, or volume-controlled with decelerating flow. This part is no different from assist-control ventilation.

Unlike assist-control, in SIMV any spontaneous breathing by the patient does not result in a machine-delivered breath. In other words, he gets what he can get. For example, if the SIMV settings include a rate of 10 and a tidal volume of 500 mL, the patient is guaranteed to get 10 breaths of 500 mL per minute. If he breathes, say, 10 times a minute over the set rate, then he gets whatever volume of gas he can pull through the circuit. This will be variable and depends on the patient's strength, compliance, and degree of effort. The tidal volumes on SIMV may look like this (machine-delivered breaths in plain type, and spontaneous tidal volumes in bold):

500 – 254 – 500 – 500 – 500 – 399 – 500 – 526 – 122 – 500 – 500
--

This is all well and good if the patient is strong enough to pull adequate tidal volumes. If he's not, however, then breathing on SIMV can lead to a much higher work of breathing due to ineffective spontaneous ventilation. It is easier to breathe fast than deep, and someone with weak respiratory muscles may have a spontaneous respiratory rate of 30 but tidal volumes in the 150-180 mL range. In other words, barely more than the anatomic dead space! This wasted ventilation can rapidly lead to fatigue.

In order to get around the problem of ineffective spontaneous ventilation, modern ventilators can augment the patient's spontaneous efforts with Pressure Support (PS). PS is the pressure the ventilator applies whenever it detects the patient taking a breath on his own—it does not apply to machine-delivered breaths. This is why there's no PS in assist-control ventilation, where spontaneous efforts by the patient result in a full machine-delivered breath. The weaker the patient's effort, the more PS is needed to deliver an adequate tidal volume. The PS can therefore be adjusted based on the patient's total respiratory rate, spontaneous tidal volumes, and comfort. This is explained in more detail in the chapter about pressure support ventilation.

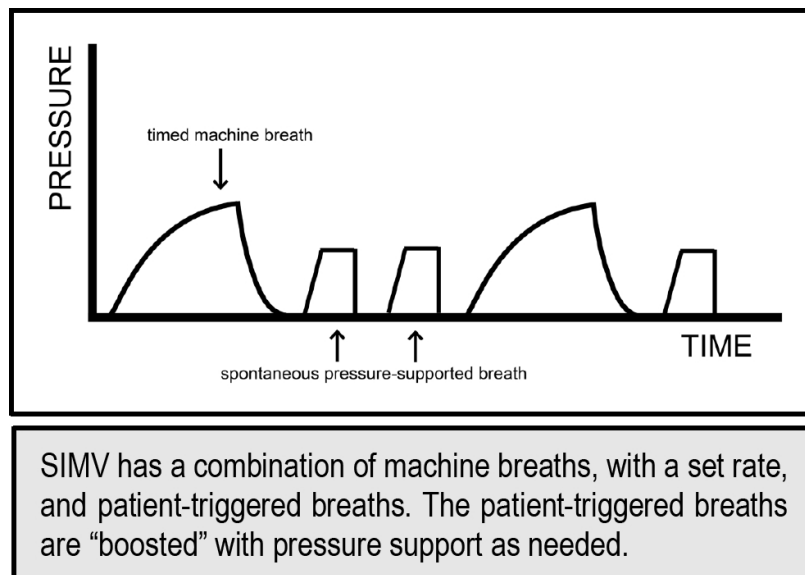

When a patient is first placed on SIMV, the rate and tidal volume should be set similarly to how you would do it for assist-control ventilation. That is, the tidal volume should be 6-8 mL/kg predicted body weight (4-6 mL/kg for ARDS), with



a rate between 12 and 18 breaths per minute. The pressure support is usually set at 10 cm H<sub>2</sub> O; if the spontaneous tidal volumes are unacceptably low (below 3-4 mL/kg), then the PS can be increased. As the patient recovers from acute respiratory failure, the ventilator rate is lowered while the PS is maintained. This means that the patient is depending more on his spontaneous ventilation and less on the machine. This continues until he's ready for extubation.

IMV, and later SIMV, was introduced as a method for weaning patients from mechanical ventilation sooner than could be done with assist-control. This has never been proven, though, and for good reason—the ventilator is a support mechanism and cannot do anything to make the patient recover from his illness or injury. In other words, the patient will come off the vent when he's ready, no matter what the mode of ventilation. Progressive loading of the respiratory muscles using pressure support and a reduction in the ventilatory rate hasn't been shown to improve outcomes, either. To date, the most effective method of weaning is the daily spontaneous breathing trial on either a T-piece or low-level pressure support ventilation. <sup>8</sup>

Claims of preventing diaphragmatic atrophy are likewise unfounded—the diaphragm is a muscle that contracts throughout life and being on assist-control ventilation will not stop this. Atrophy of respiratory muscles is a problem with prolonged neuromuscular blockade, administration of corticosteroids, poor nutrition, and critical illness. **None of these can be prevented with a particular mode of ventilation.**

Despite this, there is nothing wrong with SIMV as long as you pay attention to the patient's work of breathing and comfort, and supplement his efforts as needed with pressure support and an adequate number of machine-delivered breaths. Daily spontaneous breathing trials should still be performed. It really comes down to the preference of physicians and respiratory therapists in a particular institution and what they feel comfortable using to treat patients.

# Chapter 10

## Pressure Support Ventilation

So, let's say that a patient has a competent drive to breathe but is not quite ready for unassisted breathing. Pressure support ventilation (PSV) allows the patient to breathe spontaneously. In fact, he has no choice—there's no set rate in PSV. Whether he breathes 4 times a minute or 40, that's what he gets.

PSV should not be used on patients who are deeply sedated or who are receiving neuromuscular blockade (which is just common sense). It's not the best mode for patients who are in shock, or who have high metabolic requirements, or who have severe lung injury or ARDS. In those cases, modes like assist-control are better. A/C is also better when the patient's breathing is, shall we say, unreliable—drug overdoses, status epilepticus, neuromuscular diseases, brainstem strokes, and high cervical spine injuries all can compromise a patient's ability to ventilate adequately.

Think of PSV as more of a “recovery mode.” Once the worst of the initial illness or injury is over, and once the patient shows that he's able to maintain his own ventilation with a little help from the ventilator, consider using pressure support.

The pressure support provided by the ventilator augments the patient's effort. When the patient triggers the ventilator—when he initiates a breath and the ventilator senses it—the machine will increase the pressure in the circuit to a set level, permitting gas to flow from the ventilator into the patient's lungs. How much volume is delivered depends on the compliance of the respiratory system. Remember: compliance is the change in volume divided by the change in pressure. So, if the pressure support is set at 10 cm H<sub>2</sub>O and a tidal volume of 400 mL is delivered, then the compliance of this patient's

respiratory system is 40 mL/cm H<sub>2</sub> O. As compliance improves (e.g., with resolution of pulmonary edema, or improvement in respiratory muscle strength, or after drainage of a large pleural effusion), the amount of pressure necessary to generate a given tidal volume goes down. Think of pressure support as a boost that the patient needs to get an adequate tidal volume when he's breathing on his own.

If the triggering of the ventilator by the patient is what tells the machine to raise the pressure, or give the boost, then what tells it to stop? The answer is flow. When the ventilator first raises the pressure to, say, 15 cm H<sub>2</sub> O, the flow of gas into the patient's lungs is at its maximum. As the lungs fill, the constant pressure will deliver less and less gas. If nothing told the ventilator to stop, gas would continue to flow until the pressure in the patient's lungs equaled the set level of pressure support. As you might imagine, this would be pretty uncomfortable. The solution is to flow-cycle the vent. The ventilator can be programmed to drop the pressure back down to baseline (either zero, or whatever the PEEP may be set at) when the inspiratory flow drops to a certain percentage of the initial rate. This is usually set at 25%, but it can be changed to improve patient-ventilator synchrony.

For example: a patient is receiving pressure support ventilation. The vent is set with a positive end-expiratory pressure (PEEP) of 5 cm H<sub>2</sub> O and a pressure support (PS) of 15 cm H<sub>2</sub> O. There is no set rate or tidal volume—remember, in PSV the patient is responsible for his own breathing. The PS is a boost that, depending on his compliance, will generate some sort of tidal volume. The flow-cycle (the signal for the ventilator to stop the PS) is 25%.

When the patient triggers the ventilator, the pressure rises from 5 (the PEEP) to 20 (PEEP + PS). At the beginning of the breath, the inspiratory flow is 40 liters per minute. The ventilator will keep the system pressurized at 20 cm H<sub>2</sub> O, allowing gas to flow into the patient's lungs, until the inspiratory flow falls to 10 liters per minute (25% of the initial flow). At that point, the ventilator drops the pressure back down to 5 cm H<sub>2</sub> O. The patient can exhale passively.

How much PS to provide depends on the patient. Remember, pressure support is a boost. If the patient gets tired, or if his compliance gets worse (pneumonia, pulmonary edema, etc.), he will need more PS. As he gets stronger, the PS can be dialed down. The best way to judge how much PS is necessary is to watch the patient. Another example: a woman on PSV has a set PEEP of 5 cm and a set PS of 10 cm. Her respiratory rate is in the high 30s and her tidal volume is in the low 200s. Clearly, this is not enough support! Let's say you increase the PS up to 20 cm. Now, her respiratory rate is 8 breaths per minute. Her tidal volume is now between 800 and 900 mL. She's certainly more comfortable—almost *too* comfortable. A nice tidal volume is between 6-8 mL/kg of predicted body weight. Unless she's a 6'10" WNBA player, this is too much of a tidal volume. Lowering the PS to 14 cm leads to a respiratory rate of 16-20 and a tidal volume of 380-450 mL. Perfect. Looking at the patient is important—accessory muscle use, diaphoresis, tachycardia, and paradoxical abdominal breathing (where the chest and abdomen move dysynchronously) are all signs that the ventilator, as currently set, is not meeting her needs.

Weaning on PSV is pretty simple—as the patient gets better, she'll need less of a boost to breathe comfortably. As her strength improves, you can lower the PS (as described above). Once the level of PS needed for comfortable breathing is less than 10 cm H<sub>2</sub>O, it's time for a spontaneous breathing trial. This is such an important topic that it has its own chapter in this book.

## **Volume Support Ventilation**

Hopefully by now, you're convinced that PSV is a good thing. It does have some drawbacks, however. The first, and most serious, is that there is no set ventilator rate (I know I've mentioned this already, several times, but it bears repeating). A patient who keeps having apneic spells or who is hypercarbic despite a high level of PS should be switched to a more controlled mode of ventilation.

The second drawback is the unreliable tidal volumes generated by PSV. By unreliable, I don't mean that they can't

be trusted. I do mean, however, that the tidal volume can vary greatly during PSV. Remember, in PSV the pressure support is fixed. The tidal volume generated depends on compliance and respiratory muscle strength. If the patient starts tiring out, or if the compliance gets worse, the tidal volume will fall (and the patient's respiratory rate will go up, as an attempt to maintain the same minute ventilation). A man may look great on morning rounds with a PEEP of 5 and a PS of 10—tidal volumes in the 500s, respiratory rate below 20, smiling around the endotracheal tube. By midafternoon, however, he may be getting tired. The ventilator still takes the pressure from 5 to 15 cm (PEEP + PS) every time he triggers the vent, but now he's pulling tidal volumes of 300 mL and his respiratory rate is 35. Not ideal.

One solution to this problem would be to ask the respiratory therapist to stand by the ventilator all day long. When the tidal volume is higher than desired, he could reduce the PS; when the tidal volume drops below what's wanted, he could increase the PS. For example: on rounds, we decide that a decent tidal volume for our patient is 450 mL. After playing with the vent, we find that a PS of 12 cm H<sub>2</sub>O produces a tidal volume of 450, give or take a few mL. Our trusted respiratory therapist goes to work. With hawk-like vigilance, he watches the tidal volume. It drops to 390—in a flash, he increases the PS to 15, bringing the tidal volume back to 450. But wait—now the tidal volume is 520 mL! Down comes the PS to 13. And so, on it goes, for what seems like a very long shift.

This solution would be a tremendous waste of manpower. What if, instead of having a dedicated respiratory therapist by each ventilator, we could ask the vent to do the work? That's what volume support ventilation is. You set a desired tidal volume and PEEP, and the ventilator automatically adjusts the pressure support up or down to get to the desired volume. The ventilator's computer analyzes the tidal volumes every three breaths and makes the adjustment. It is still pressure support ventilation—there's no set ventilator rate, and the breaths are flow-cycled—but now, the PS is working in the background and is variable.

Volume support ventilation (VSV) is a natural progression of PSV with newer ventilator technology. It adjusts to changes in patient compliance and respiratory effort while still permitting spontaneous breathing. It's easy to know how well the patient is doing on VSV—just look at the patient and at the peak airway pressure. Remember, the peak airway pressure is the sum of the PEEP and the delivered pressure support (so, a PEEP of 5 and a PS of 10 would lead to a peak airway pressure of 15 cm). VSV adjusts the PS up and down to get to a desired volume. So, let's say the desired volume is 450 mL and the PEEP is 5 cm. When we first put our patient on VSV, his peak airway pressure is 17 cm. This means that the PS necessary to get the volume we want is 12 cm ( $17 - 5$ ). The next day, the peak airway pressure is 22 cm. This means that the patient needs more pressure—more of a boost—than he did before.

The day after that, the peak airway pressure is now 9 cm. The patient looks better, and he needs less of a boost to get his tidal volume of 450 mL. Definite improvement. In fact, since he needs a PS less than 10 cm H<sub>2</sub> O, it's time for a spontaneous breathing trial.

# Chapter 11

## PEEP and CPAP

In high-school science, we were taught that breathing in brings oxygen to the bloodstream and breathing out clears carbon dioxide from the body. This is true—in a bulk flow of gas sense. However, we know that gas exchange doesn't stop when you stop breathing for a few seconds, or even a few minutes. Pulmonary blood flow and alveolar gas exchange still occur, in a space called the functional residual capacity (FRC). The FRC is the “reserve zone” of the lung that maintains these vital functions even during temporary interruptions in breathing (like when you swim underwater or get a piece of meat lodged in your larynx). If we didn't have this, it would be tough to survive!

If you were lying in bed and someone dropped a large heavy sandbag onto your chest, you would immediately find it difficult to breathe. This is because the weight is impairing the excursion of your respiratory muscles and compressing the FRC. On the other hand, if you were warned about the weight a few seconds before it was dropped on you, you would take a breath in and splint your chest and abdominal muscles to limit the impact. You're probably doing this right now, just thinking about the weight falling onto your chest.

One more illustration—if you were to ride in a car and hang your head out the window at highway speeds, you would feel a rush of air into your mouth whenever you breathed in, and a resistance whenever you exhaled. This, in effect, is what continuous positive airway pressure (CPAP) is—a pressure applied to your respiratory system during both inhalation and exhalation. CPAP is applied during spontaneous respiration.

Positive end expiratory pressure (PEEP) is very similar, and is the term used for this pressure-splint applied during mechanical ventilation. It's not truly CPAP, since the inspiratory pressure from the vent is also positive, but it functions in a nearly identical manner as a way to splint open

alveoli that would otherwise collapse, maintaining or augmenting the FRC. Semantically, PEEP is the term used during A/C or SIMV, while CPAP is used for noninvasive ventilation or during pressure-support ventilation.

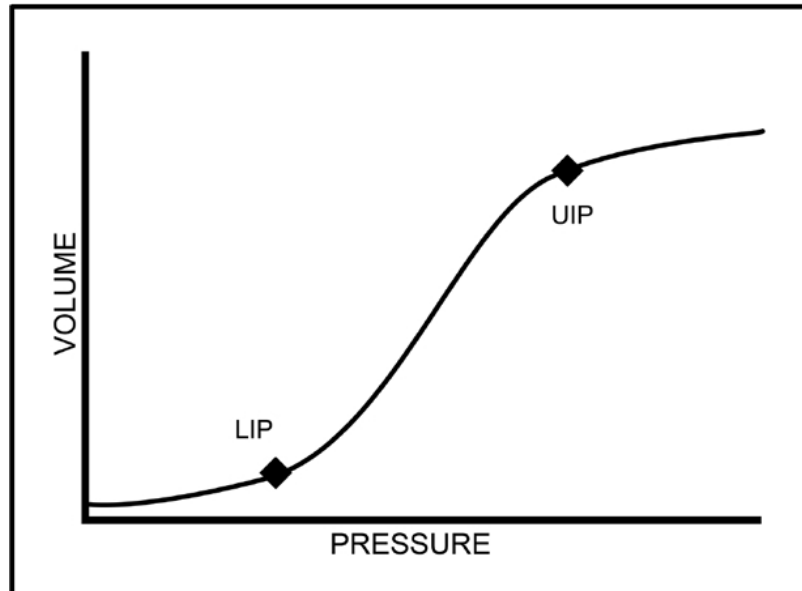

In a fully deflated lung, it takes an escalating amount of pressure to “pop open” the alveoli. Once that point is reached, the lung inflates easily. This “pop open” point is known as the Lower Inflection Point (LIP) and illustrates the PEEP needed to open and stabilize flooded alveoli.

As the lung inflates, it will reach a point where it's fully expanded and where further application of pressure doesn't increase the volume. This is known as the Upper Inflection Point (UIP). The UIP marks the point where alveoli can be overdistended.

This graphical representation is a good way to understand lung compliance. In clinical practice, however, determining the LIP and UIP in a ventilated patient can be very difficult.

PEEP and CPAP also have a beneficial effect on left ventricular function. Increased intrathoracic pressure reduces preload by a mild degree, which can help with decompensated congestive heart failure. Importantly, PEEP and CPAP also reduce left ventricular afterload. Afterload is represented by the transmural pressure across the ventricle—in other words, the pressure inside the ventricle (systolic pressure) minus the



pleural pressure. Since CPAP and PEEP increase the intrathoracic pressure, in turn increasing the pleural pressure, the difference between the two (the afterload) is reduced. This has a positive effect on left ventricular function.

As a general rule, PEEP should be used to correct hypoxemia when the chest X-ray has white stuff where it should be black—in other words, use PEEP when there is radiographic airspace consolidation or infiltration.

Most of the time, when you first put a patient on mechanical ventilation the PEEP will be set between 3 and 5 cm H<sub>2</sub> O. Theoretically, this helps prevent atelectasis in the dependent lung areas and maintains ventilation-perfusion matching. In reality, it's usually done because, well, that's how it's done! This low level of PEEP is generally not harmful.

In more severe hypoxemic respiratory failure, most notably ARDS, increasing the PEEP can improve gas exchange and lung recruitment. The optimal PEEP is not known, but a level of 8-15 cm H<sub>2</sub> O is usually sufficient. The ARDSNet trial used a PEEP/FiO<sub>2</sub> table that required a PEEP of 18-24 when breathing 100% oxygen.<sup>4</sup> The subsequent ALVEOLI trial <sup>2</sup> compared higher and lower levels of PEEP and didn't find a mortality benefit to either strategy, but it's important to note that PEEP was used in both arms.

Increasing PEEP until compliance improves and oxygenation is adequate is an acceptable strategy. Pay attention to the plateau pressure—if the plateau pressure increases more than the rise in PEEP, then recruitment is not occurring, and the lungs may be overdistended. Using a decelerating PEEP titration approach is also acceptable—set the PEEP at 20 cm H<sub>2</sub> O with a tidal volume of 6 mL/kg predicted body weight. Set the FiO<sub>2</sub> at a level sufficient to keep the oxygenation adequate (SpO<sub>2</sub> 88-94%). Every 3-5 minutes, reduce the PEEP in 1-2 cm increments, following the oxygen saturation and the patient's compliance. When the SpO<sub>2</sub> falls below 88%, or the compliance worsens, set the PEEP at 1-2 cm above the level where that happens.

The major complication of excessive PEEP is overdistension of alveoli leading to impairment of venous return (and hypotension) or impairment of gas exchange by compressing pulmonary capillary beds. Impairment of venous return usually doesn't happen with a PEEP less than 10-12 cm H<sub>2</sub> O—if the blood pressure falls at this level of PEEP, the patient is usually hypovolemic, and a fluid challenge is warranted. If overdistension of alveoli is affecting gas exchange, it will be in the form of increased dead space (ventilation without perfusion)—the PaCO<sub>2</sub> will rise and the PaO<sub>2</sub> will fall.

Despite what you might hear, PEEP is not the major cause of ventilator-induced lung injury (VILI).<sup>6</sup> VILI is primarily due to excessive alveolar distension during inspiration and is a consequence of *volutrauma*, not barotrauma. Excessive tidal volumes, independent of the distending pressures, can lead to alveolar damage, pulmonary interstitial emphysema, pneumothorax, and pneumomediastinum. This is the rationale behind using more physiologic tidal volumes (4-8 mL/kg) than has been done in the past.<sup>4</sup>

Once the FiO<sub>2</sub> requirement is below 50-60%, PEEP can be reduced in a stepwise fashion as tolerated. If the compliance worsens, or the patient becomes hypoxemic, this indicates alveolar derecruitment. The usual stopping point is 5 cm H<sub>2</sub> O, but this is admittedly arbitrary. Generally, patients who have adequate oxygenation on 40% oxygen and 5 cm PEEP are ready for spontaneous breathing trials and assessment for extubation .

### Setting PEEP by Chest X-ray

Chest X-Ray	Initial PEEP
Clear	5 cm H <sub>2</sub> O
Scattered Infiltrates	10 cm H <sub>2</sub> O
Diffuse Dense Infiltrates	15 cm H <sub>2</sub> O
Bilateral White Out	20 cm H <sub>2</sub> O

## Setting PEEP by Oxygenation in ARDS<sup>10</sup>

Degree of ARDS	PaO <sub>2</sub> /FiO <sub>2</sub> Ratio	PEEP
Mild	201-300	5-10 cm H <sub>2</sub> O
Moderate	101-200	10-15 cm H <sub>2</sub> O
Severe	≤ 100	15-20 cm H <sub>2</sub> O

### Using the ARDSNet PEEP Tables

- Go up and down the table as needed to keep the PaO<sub>2</sub> 55-80, or the SpO<sub>2</sub> 88-94%
- According to the ALVEOLI study,<sup>9</sup> there is no proven benefit with using one table over the other, so pick according to the clinical condition—a patient with unstable hemodynamics or a pneumothorax may do better with the “Lower PEEP” approach, while a patient with significant blunt chest and abdominal wall trauma or obesity may benefit from the “Higher PEEP” strategy.
- In a randomized trial of 1010 patients, an aggressive “high PEEP” strategy coupled with recruitment maneuvers was associated with a higher 6-month mortality (65.3% vs. 59.9%).<sup>11</sup> These findings support using a lower PEEP strategy in the majority of patients with ARDS.

**Lower PEEP Table**

<b>FiO<sub>2</sub></b>	<b>PEEP</b>
30%	5
40%	5
40%	8
50%	8
50%	10
60%	10
70%	10
70%	12
70%	14
80%	14
90%	14
90%	16
90%	18
100%	18
100%	20
100%	22
100%	24

**Higher PEEP Table**

<b>FiO<sub>2</sub></b>	<b>PEEP</b>
30%	5
30%	8
30%	10
30%	12
30%	14
40%	14
40%	16
50%	16
50%	18
50%	20
60%	20
70%	20
80%	20
80%	22
90%	22
100%	22
100%	24

# Chapter 12

## Trigger and Flow

### Triggering

Triggering is the term used to describe how a patient lets the ventilator know that he wants a breath. There are two types of triggering mechanisms—those that detect a change in pressure, and those that detect a change in flow.

Pressure triggering requires the patient to drop the end expiratory pressure by a preset amount— usually in the 1 to 4 cm H<sub>2</sub> O range. This normally doesn't require a lot of effort. If the PEEP is set at 5 cm and the trigger is 2 cm, then the patient has to lower the pressure in the endotracheal tube to 3 cm H<sub>2</sub> O in order for the ventilator to recognize that he wants a breath and to deliver it. Pressure triggering can be problematic in patients with chronic obstructive pulmonary disease, asthma, or other conditions that predispose to dynamic hyperinflation (auto-PEEP). As an example, let's say that our patient has a set PEEP of 5 but has an intrinsic, or auto, PEEP of 12. In order for the patient to trigger a breath with a 2 cm trigger, he has to get the end-expiratory pressure down to 3 cm ( $5 - 2 = 3$ ). With an intrinsic PEEP of 12 cm, this requires him to generate a negative pleural pressure of 9 cm to trigger the vent. This is pretty difficult, to say the least.

Ineffective triggering can be recognized on physical exam by watching for inspiratory efforts that don't lead to a machine-delivered breath. I place my hand on the patient's chest—if I feel him trying to breathe and the vent doesn't cycle, or if there's a noticeable delay between his effort and the delivered vent, then triggering is ineffective. This can also be seen with an esophageal pressure probe, which reflects changes in pleural pressure. Negative deflections on the probe that don't correlate with ventilator cycling tell you that the patient is unable to trigger the ventilator. Physical examination

is easier than placing an esophageal probe and is about as reliable.

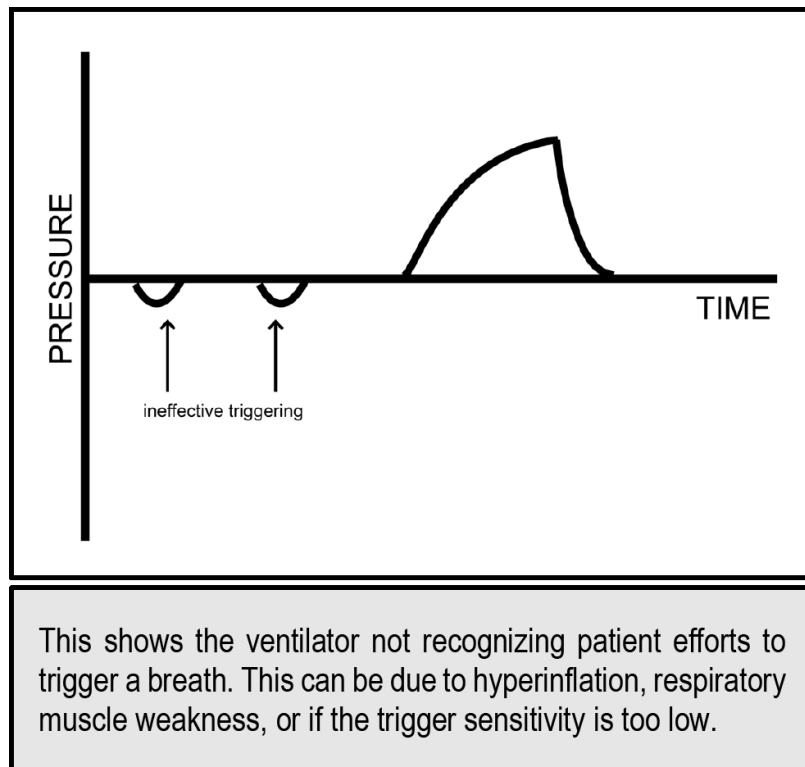

In order to make triggering easier, most ventilators will also allow the trigger to be initiated by changes in inspiratory flow. The trigger is usually in the range of 1 to 6 liters per minute and is independent of the patient's intrinsic PEEP. With flow triggering, the potential problem is the opposite of that seen with pressure triggering. If the flow trigger is too low, then it may "auto-cycle" the ventilator even when the patient isn't trying to get a breath. Oscillations in the ventilator tubing from water or secretions, hyperdynamic cardiac contractions, and patient movement may all be picked up by the ventilator as a change in flow and lead to a breath being delivered. On the ventilator's screen, multiple breaths stacked together indicate that this is happening. The solution is to make the trigger less sensitive, or switch to pressure triggering.

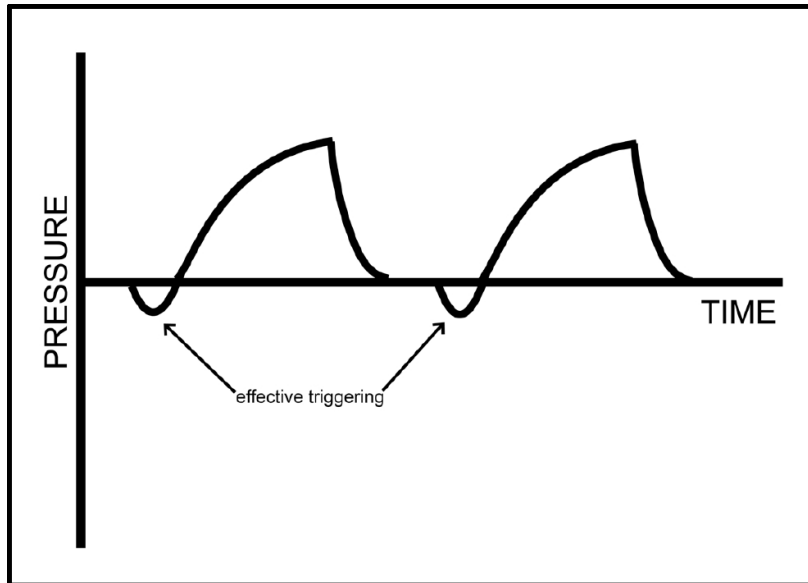

Effective triggering leads to a ventilator-delivered breath immediately following the patient's effort to breathe.

## Flow

When you and I breathe, the inspiratory flow pattern is sinusoidal. Flow rapidly increases until the lungs are nearly at the tidal volume, and then it decelerates until the inspiratory flow is zero. Exhalation then occurs passively. When positive pressure ventilation is being used, the flow pattern is either constant or decelerating.

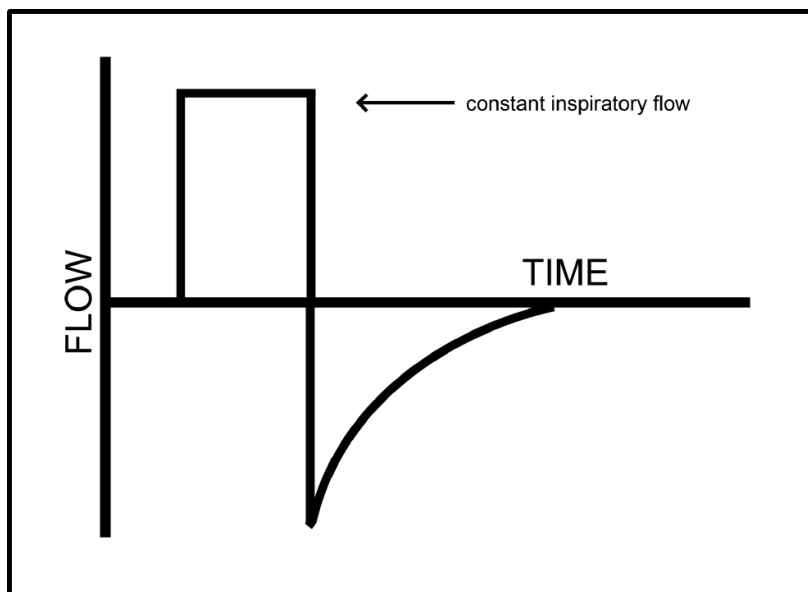

Constant flow is the pattern seen in older ventilators using volume control. When the ventilator gives a breath, it opens

the valve and delivers gas at a constant rate until the target volume is reached, then shuts off the gas. This would be similar to using a compressed air hose to fill a balloon—the air will enter the balloon at a constant rate until you let go of the trigger. This appears to be a square-topped waveform on the ventilator. Constant flow is perceived by many patients to be uncomfortable—after all, it's like drinking from a fire hose. It also leads to higher peak airway pressures (but not higher plateau pressures—the pressure difference is transmitted to the endotracheal tube and the conducting airways).

Decelerating flow is the pattern seen during pressure control ventilation, pressure support ventilation, and pressure-regulated volume control; newer ventilators will also let you select this flow pattern for volume control ventilation. With decelerating flow, the waveform looks like a sloping roof. When the breath first starts, the flow is at its peak. As the lungs fill with air, the inspiratory pressure stays constant and the flow decelerates.

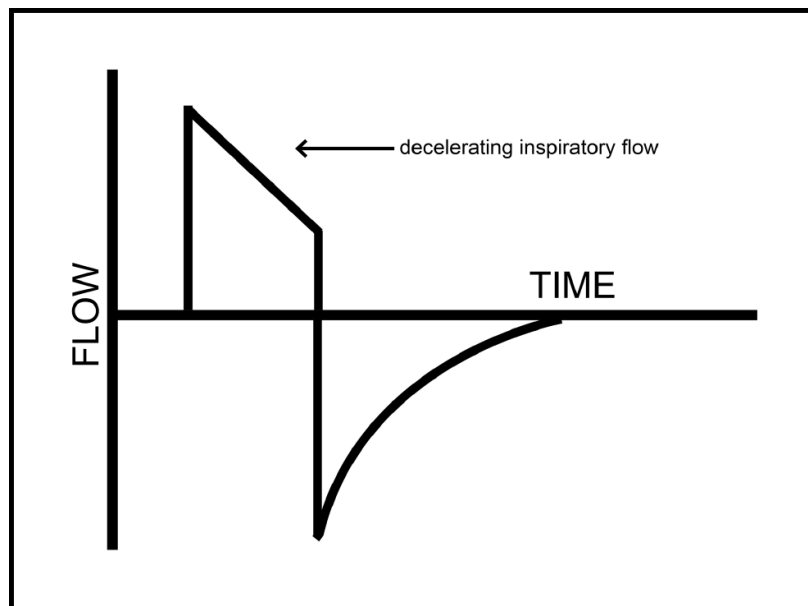

If constant flow is like drinking from a fire hose, then decelerating flow is like filling a glass of lemonade from a pitcher. Initially, the lemonade flows pretty quickly from the pitcher to the glass. As the glass fills, the pourer will lift up the pitcher gradually so that the flow of lemonade decelerates. Right as the glass becomes completely full, the flow stops. Now, imagine that the glass looks like a cast of the airways



and alveoli. If you're trying to fill a complex structure with lemonade, you want to slow the flow even more to make sure all of the nooks and crannies get filled. If you extend this analogy to ventilation, it then seems that decelerating flow would result in better gas distribution to less compliant areas of lungs (which it does).

Most patients seem to tolerate decelerating flow better. Some patients, however, seem to do better with constant flow. People with COPD exacerbations or status asthmaticus often have significant air hunger and they want to get the air into their lungs quickly. Slowing the flow rate can make the dyspnea and air hunger worse.

### **Dynamic Hyperinflation**

Expiratory flow is passive and is determined by the elastance of the lungs and the airway resistance. Elastance is the reciprocal of compliance—the change in pressure over the change in volume. A lung with high elastance will recoil and empty much more quickly than one with a low elastance (or, high compliance). A stiff lung with little airway resistance doesn't take much time to empty at all—the air just rushes out. On the other hand, compliant (low elastance) lungs with high airway resistance will take much longer to empty. The latter is seen with COPD and exacerbations of asthma. Getting air into the lungs is no problem but getting air out can be difficult (due to decreased recoil, or narrow inflamed airways, or both). On the ventilator, it's important to look at the expiratory flow waveform and to make sure that the flow is coming back up to baseline, or zero. If not, then this can lead to dynamic hyperinflation (auto-PEEP). If it's severe enough, the increased intrathoracic pressures can compromise venous return to the heart.

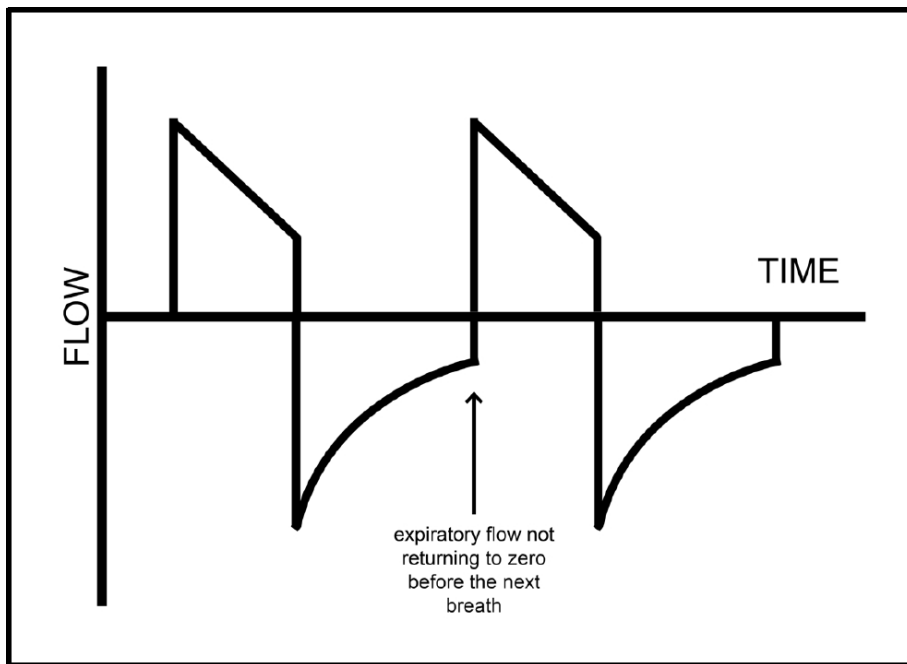

Dynamic hyperinflation is usually evident on physical exam. The patient often appears uncomfortable, and the abdominal muscles contract during exhalation (he's trying to force the air out). Loud wheezing throughout the expiratory phase can be heard. Neck veins may also be distended, depending on the degree of auto-PEEP. On the ventilator, you will see that the expiratory flow is not coming back to the zero baseline. If you pause the ventilator at the end of expiration (an expiratory pause maneuver) for 0.5-1.0 seconds, you can see what the alveolar end-expiratory pressure is. If it's higher than the set PEEP, then auto-PEEP is present.

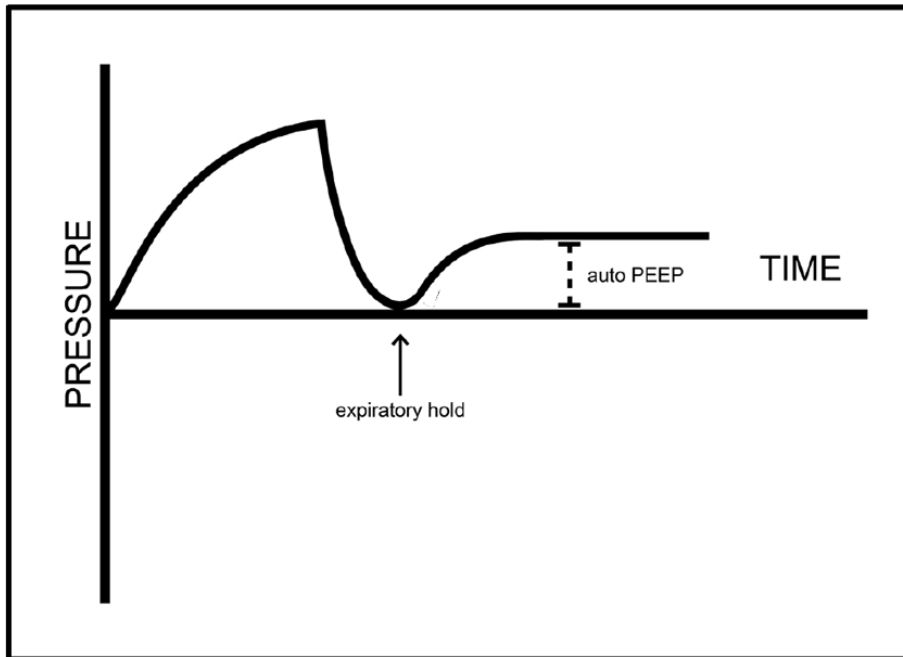

The end-expiratory pressure represents the equilibration of pressures throughout the lungs when flow is stopped. This is the best assessment of the alveolar pressure. If the pressure at end-expiration exceeds the applied (set by the machine) PEEP, then there is autoPEEP present. Normally, there should be no difference between the end-expiratory pressure and the set PEEP.

When dynamic hyperinflation occurs, the ventilator should be adjusted to allow the gas to escape completely during exhalation. This may mean lowering the ventilator rate and shortening the inspiratory time. Bronchodilators and steroids can help with the airway resistance; adequate sedation should be used to minimize agitation and tachypnea.

If the patient has COPD and auto-PEEP, you can try to splint open the conducting airways with some applied PEEP. This is possible because in COPD, the loss of recoil due to destruction of surrounding alveoli and bronchioles leads to collapse of the small airways when the expiratory flow increases. You may recall Bernoulli's Law, which says that as velocity increases, pressure decreases. This is how an airplane can fly, and it's why roofs blow off houses during tornados (the air pressure in the house is greater than the pressure outside). In this case, as airflow increases, the airways collapse

because the surrounding lung parenchyma that normally holds them open has been damaged or destroyed. Splinting the airways with PEEP or CPAP helps prevent this dynamic collapse and hyperinflation.

Applying a pressure that's about 75-85% of the measured auto-PEEP will keep the airways open but still allow expiratory flow to occur. <sup>12</sup> This is the so-called "waterfall effect." If a river is rushing down a canyon toward a waterfall, the point at which the water goes over the falls is the critical point—very turbulent, very chaotic. If you wanted to keep the water going downstream but not have it be quite so turbulent, you would somehow have to raise the water level of the river below the falls until it was at the critical point—then, water could continue to flow down the canyon but without the chaos of the waterfall. In the analogy, the critical point is the pressure at which the small airways collapse during exhalation, trapping gas in the alveoli behind them. Raising the applied PEEP with the ventilator to about 75-85% of the alveolar pressure stabilizes the critical point—that is, it raises the river level enough to permit exhalation but not airway collapse. Increasing the applied PEEP above the alveolar pressure would have the same effect of raising the river above the height of the falls—the air would flow backwards, and the hyperinflation would worsen.

# Chapter 13

## High Frequency Oscillatory Ventilation

Numerous studies have shown the benefit of low tidal volume ventilation in ARDS.<sup>4, 9</sup> The primary determinant of ventilator-induced lung injury seems to be volutrauma, so it makes sense to keep the tidal volume as low as possible while maintaining adequate gas exchange.<sup>6</sup> High frequency oscillatory ventilation (HFOV) aims to do this using ultra-fast tidal volumes that are less than the patient's anatomic dead space.

Watch a dog pant—he's not pulling in very much tidal volume, but somehow, he's still alive. This is basically the premise behind HFOV. A mechanical diaphragm oscillates between 3 and 15 times a second. This creates a “push-pull” action on the column of air extending from the endotracheal tube all the way to the alveoli.

### Mechanisms of Gas Exchange in HFOV [13](#)

**Direct convective gas flow:** some alveolar beds are close enough to the large airways that oxygen-rich gas is carried into them, and carbon dioxide-rich gas is ventilated away. This makes up a small portion of total gas exchange in HFOV, but is the primary mechanism of gas exchange in conventional ventilation.

**Taylor Dispersion:** the theory behind this is that the inspired gas is pushed down the center of the column by the oscillatory pressure, while the gas from the alveoli remains along the outer edge of the column and is gradually pushed out. Conceptually, think of a piston being pushed slowly down a slightly larger cylinder of liquid. As the piston gets closer to the bottom of the cylinder, the liquid is forced out around the edges.

**Molecular Diffusion:** at the level of the respiratory and terminal bronchioles, oxygen and carbon dioxide are agitated by the turbulent gas flow created by oscillation. This results in diffusion of oxygen into the alveoli, to be taken up by the capillaries.

**Pendeluft:** this describes the to-and-fro motion of gas from one alveolar bed to another. Gas from alveoli that are better ventilated will travel into alveoli that are less ventilated, thereby improving

gas exchange. This happens via respiratory bronchioles and collateral channels between alveoli.

HFOV may be useful as a rescue mode of ventilation for severe hypoxemic respiratory failure, such as ARDS. It's also a useful mode when a patient has a large bronchopleural fistula and is losing a significant part of the tidal volume via a chest tube. The attraction is being able to increase the mean airway pressure, and thereby oxygenation, without exposing the lungs to high distending pressures and volumes (which we know are bad). HFOV has its own terminology, which is very different from conventional ventilation.

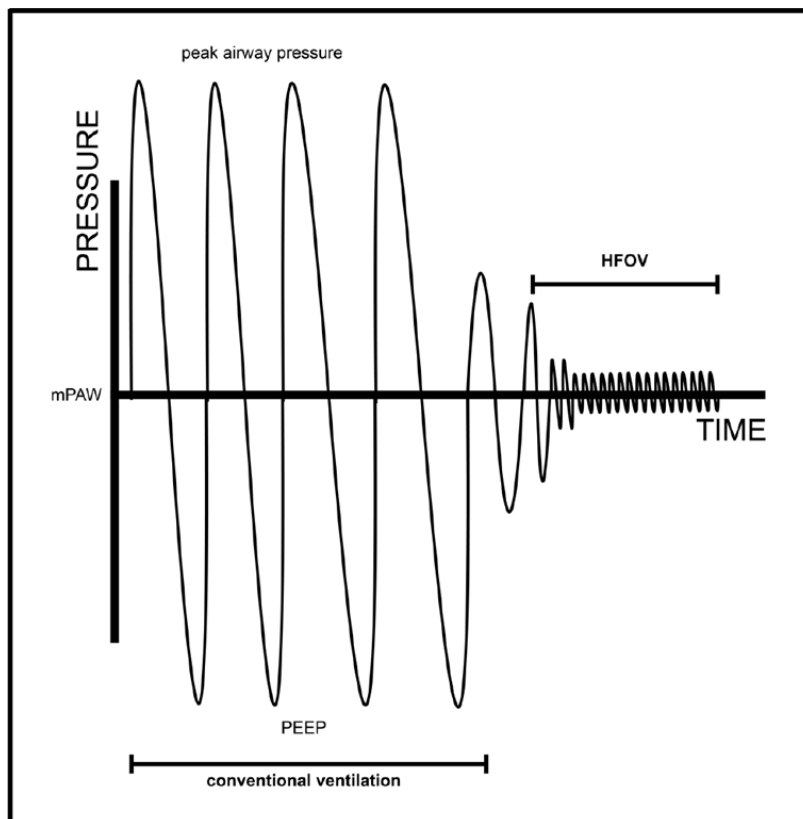

HFOV maintains a near-constant mean airway pressure (mPAW) without the large swings in pressure seen with conventional ventilation. The oscillations are measured in frequency per second (Hz), not breaths per minute.

Oxygenation in HFOV is affected by the  $\text{FiO}_2$  and the mean airway pressure (mPAW). Recruitment maneuvers can also be done by raising the mPAW and stopping the oscillations—this is essentially the same as using high-level CPAP to open up collapsed alveoli.

Ventilation is controlled by the frequency of the oscillations ( $f$ ) and the amplitude. The  $f$  is measured in Hertz, or oscillations per second. Thus, an  $f$  of 3Hz means the mechanical diaphragm is oscillating three times a second, or 180 times a minute. Here's an important point—the higher the frequency, the less convective gas flow (and more gas dispersion). This means that the tidal volume is reduced with faster oscillations. Raising the frequency (e.g. from 5Hz to 10Hz) will lower the tidal volume and lead to a rise in PaCO<sub>2</sub>. Lowering the frequency will lower the PaCO<sub>2</sub>. The frequency range on the oscillating ventilator is 3Hz to 15Hz.

Amplitude refers to the change in pressure across the oscillating diaphragm, and ranges from 8 to 90 cm H<sub>2</sub>O. While this pressure can be quite high, it's important to remember that the pressure differential will dissipate as it travels down the ventilator circuit and the large airways. At the alveolar level, this pressure change is barely noticeable. Increasing the amplitude will increase the force of oscillation and improve gas mixing. Increasing the amplitude will lower the PaCO<sub>2</sub>, while lowering it can lead to an increase in PaCO<sub>2</sub>. Generally, the amplitude is set to a level that makes the patient's thighs jiggle (scientific, I know), and ventilation is controlled by changes in the frequency.

If the PaCO<sub>2</sub> remains unacceptably high, two other changes can be made to the ventilator. Remember that Taylor dispersion is like a piston being pushed into a larger cylinder—oxygen-rich gas is in center of the gas column, being pushed slowly into the alveoli, while CO<sub>2</sub>-rich gas is on the periphery and is gradually forced out. When the gas flow stops momentarily, gas molecules diffuse evenly in the column. In HFOV, the gas “piston” travels down the column during the inspiratory time, or TI. The TI is usually set to take up 33% of the oscillatory cycle. By increasing the TI to 50%, we can push the piston more and keep the CO<sub>2</sub> on the outside of the column from mixing with the delivered oxygen. This will improve CO<sub>2</sub> excretion.

Likewise, we can make the column a little wider to force out more of the CO<sub>2</sub>. Normally, exhaled gas escapes through the endotracheal tube. To allow more CO<sub>2</sub>-rich gas to be cleared, we can create a leak around the tube's cuff. This is referred to as a 5 cm cuff leak. To do this, deflate the cuff until the mPAW drops by 5 cm H<sub>2</sub>O. Then, increase the bias flow (inspired gas flow) until the mPAW returns to its original level.

### **Initial HFOV Settings [14](#)**

- Set the FiO<sub>2</sub> at 100%
- Set the mPAW at 45 cm H<sub>2</sub>O and hold at this level for 45 seconds (recruitment maneuver)
- After the recruitment maneuver, set the mPAW at 35 cm H<sub>2</sub>O
- Amplitude of 80, adjusted to see jiggling thighs
- Frequency of 5Hz
- T<sub>I</sub> 33%

Adjustments to HFOV can be made as described above. In severe respiratory failure, where you are likely to be using HFOV, you need to remember that having a perfect-looking ABG is not necessary or even desirable. Use the lowest FiO<sub>2</sub> needed to keep the PaO<sub>2</sub> 55-70 and tolerate hypercapnia as long as the pH is in the 7.20 – 7.35 range.

As oxygenation improves, wean the FiO<sub>2</sub> and the mPAW. Once the patient can maintain acceptable gas exchange with a mPAW of 24 and an FiO<sub>2</sub> of 50%, it's time to consider switching back to conventional ventilation.

### **Limitations of HFOV**



So, what's the downside to HFOV? As it turns out, there are several. First, there's only one commercially available ventilator in the U.S. that can provide HFOV for adults, at least at the time of this writing—the SensorMedics 3100B (Viasys® Healthcare, Yorba Linda, CA). This vent can't do anything else, so switching from conventional ventilation to HFOV, or vice versa, requires a ventilator change. Second, there are no alarms on the ventilator to tell you that there's something wrong with the patient. There is no high-pressure alarm or low tidal volume alarm or apnea alarm. This means that clinical examination needs to be very thorough, and you will end up ordering a lot of ABGs and chest X-rays. Third, it's difficult to clear secretions without convective gas flow. Mucus plugging is a common problem with the oscillator. Fourth, HFOV is not exactly a comfortable mode for the patient. He can't breathe spontaneously, and he may not like all that jiggling. As such, heavy sedation and sometimes even neuromuscular blockade are necessary.

Fifth, and most importantly, current medical evidence doesn't support the routine use of HFOV. The OSCILLATE trial, published in 2013, was a multicenter trial examining the use of HFOV early in the treatment of moderate-to-severe ARDS. <sup>15</sup> The investigators found no evidence of benefit and a trend toward increased in-hospital mortality. This was validated by the OSCAR trial, another multicenter trial of HFOV in ARDS that found similar results. <sup>16</sup> For this reason, HFOV should be limited to those patients who have a specific need like a large bronchopleural fistula, or those with truly refractory hypoxemia ( $\text{PaO}_2 / \text{FiO}_2 < 55$ ) when other rescue therapies have either failed or are not an option.

# Chapter 14

## Airway Pressure Release Ventilation

Current understanding of lung-protective ventilation suggests that lower tidal volumes are better because they don't excessively distend the alveoli, and that a higher positive end-expiratory pressure (PEEP) is better because it keeps vulnerable alveoli from collapsing at the end of the respiratory cycle.<sup>3, 5</sup> Prevention of the repetitive collapse and reopening of alveoli reduces the shear stress and "atelectrauma" seen with ventilator-associated lung injury.<sup>6</sup>

High frequency oscillatory ventilation takes low tidal volume ventilation to the extreme, by using volumes less than anatomic dead space. Airway pressure release ventilation (APRV), on the other hand, works by taking the concept of higher PEEP and running with it.

Severely ill or injured lungs, like those seen in ARDS, pulmonary contusions, and bilateral pneumonia, are characterized by a high shunt fraction. Flooded or collapsed alveoli are perfused, but gas can't make it to the alveolar-capillary membrane. Positive pressure ventilation can reduce this shunt fraction by recruiting, reopening, and stabilizing vulnerable alveoli.

If I took a patient with ARDS and put him on a CPAP of 35 cm H<sub>2</sub>O and an FiO<sub>2</sub> of 100%, his oxygenation would improve. The continuous positive pressure would open up the alveoli, and oxygen would diffuse across the alveoli into the pulmonary capillaries. The problem, of course, would be ventilation. It's unlikely the patient could maintain his own minute ventilation, and without tidal breathing the PaCO<sub>2</sub> would rise drastically. Pushing more air in on top of a CPAP (or PEEP) of 35 would lead to very high distending pressures, even if the tidal volume were kept low.

What if, on the other hand, I didn't try to push more air in? Instead of giving a tidal volume, I can suddenly decompress the airways by lowering the pressure to zero. When that happens, air rushes out, carrying carbon dioxide with it. This would provide adequate ventilation. Of course, if I left the pressure at zero for long enough, all of the vulnerable alveoli would collapse. This would increase the shunt fraction and reopening them could cause further lung injury. The answer, then, is to depressurize the airways long enough to let the gas escape but short enough to keep the alveoli from collapsing. This is what's happening during APRV.

The terminology for APRV may sound confusing, but it's really a simple system. Think of it as breathing on CPAP with intermittent releases. The CPAP is there to keep the lungs open and to maintain oxygenation. The releases periodically clear carbon dioxide from the lungs. As an added benefit, the patient can breathe spontaneously during APRV. This goes a long way toward improving VQ matching (via spontaneous diaphragmatic activity) and patient comfort, lessening the need for sedation.

## APRV Terms and What They Mean

**First of all**, APRV™ is a proprietary term and is what this mode of ventilation is called on Dräger ventilators. It's called Bi-Vent™ on Servo ventilators, and BiLevel™ on Puritan Bennett. Some of the terms mentioned below may also have different names, depending on the brand of ventilator you're using. Despite the various names, it's all essentially the same stuff.

**P<sub>HIGH</sub>** : the CPAP, so to speak. It's the pressure applied to the airways during the majority of the respiratory cycle, and it's the pressure needed to maintain open alveoli. A higher P<sub>HIGH</sub> means a higher mean airway pressure and better oxygenation. As the patient's gas exchange and compliance improve, he'll need less of a P<sub>HIGH</sub>.

**T<sub>HIGH</sub>** : the time spent at the P<sub>HIGH</sub>. It's the time between releases. A longer T<sub>HIGH</sub> will increase the mean airway pressure (improving oxygenation), but it also means fewer releases per minute (which can raise the PaCO<sub>2</sub>).

## APRV Terms, Continued

**P<sub>LOW</sub>** : the pressure that the ventilator drops to during the releases. Generally, this is set at zero. The airways act like a natural flow resistor, so end-expiratory pressure rarely reaches zero, but having the P<sub>LOW</sub> at zero creates the highest pressure gradient and facilitates better release of gas. If you need to raise the mean airway pressure, you can increase the P<sub>LOW</sub> ; however, recognize that this will limit ventilation.

**T<sub>LOW</sub>** : the time spent at the P<sub>LOW</sub> . It's short— usually between 0.4 and 0.8 seconds. This is enough time for the gas to escape, but short enough to keep most of the alveoli for collapsing. It can be extended if necessary to ventilate more CO<sub>2</sub> , but this may lead to more derecruitment. Following the expiratory flow waveform is the best way to adjust the T<sub>LOW</sub> .

The mean airway pressure and the FiO<sub>2</sub> govern oxygenation in APRV. Because there are no distending tidal volumes, APRV lets you ventilate the patient with a higher mean airway pressure without excessively high peak airway pressures. Raising the P<sub>HIGH</sub> or prolonging the T<sub>HIGH</sub> increases the mean airway pressure. Raising the P<sub>LOW</sub> is another option but is not as helpful.

### **Initial APRV Settings**

- FiO<sub>2</sub> 100%
- P<sub>HIGH</sub> 30-35 cm H<sub>2</sub> O
- P<sub>LOW</sub> 0 cm H<sub>2</sub> O
- T<sub>HIGH</sub> 4 seconds
- T<sub>LOW</sub> 0.8 seconds, adjusted to let the peak expiratory flow drop by 50%

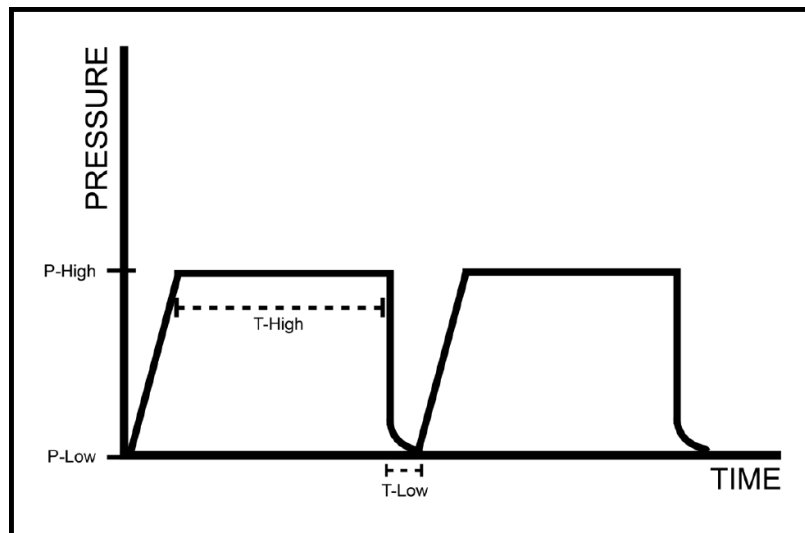

APRV uses long periods of a high pressure with brief periods of a low pressure to improve alveolar recruitment and ventilation. Think of it like CPAP with intermittent releases.

Ventilation is determined by the frequency of the releases, the time spent at TLOW, and the gradient from PHIGH to PLOW. The number of releases per minute is mainly a factor of the THIGH—the longer the THIGH, the fewer the releases and vice versa. The more releases per minute, the lower the PaCO<sub>2</sub>. Shortening the THIGH will blow off more CO<sub>2</sub>, but it can also affect oxygenation by reducing the mean airway pressure.

The compliance of the patient's lungs determines how much gas will be released. If the compliance is, say, 20 mL/cm H<sub>2</sub>O, then a drop from a PHIGH of 30 to a PLOW of zero will result in a release volume (similar to a tidal volume, in a way) of 600 mL. As the compliance improves, with either resolution of the lung injury or better recruitment of collapsed alveoli, the same pressure drop will have larger release volumes. This is one way to know if the patient is getting better.

The time spent at TLOW is also important. The longer the time, the more gas can escape (and the lower the PaCO<sub>2</sub>). However, this will lead to more alveolar derecruitment. The best way to adjust the PaCO<sub>2</sub> is to look at the expiratory flow waveform on the vent. The expiratory flow rate should drop by around 50%, and then the ventilator should repressurize to the

$P_{HIGH}$  . This seems to be the sweet spot for allowing ventilation while maintaining recruitment. Patients with COPD may need a slightly longer  $T_{LOW}$  , letting the expiratory flow fall by 75%; patients with very stiff lungs might need a shorter  $T_{LOW}$  (fall in expiratory flow of only 25%) to maintain recruitment. For the most part, keeping the drop in flow around 50% is a good starting point. Don't let the expiratory flow return to baseline—that's too much time and you'll allow a lot of alveoli to collapse.

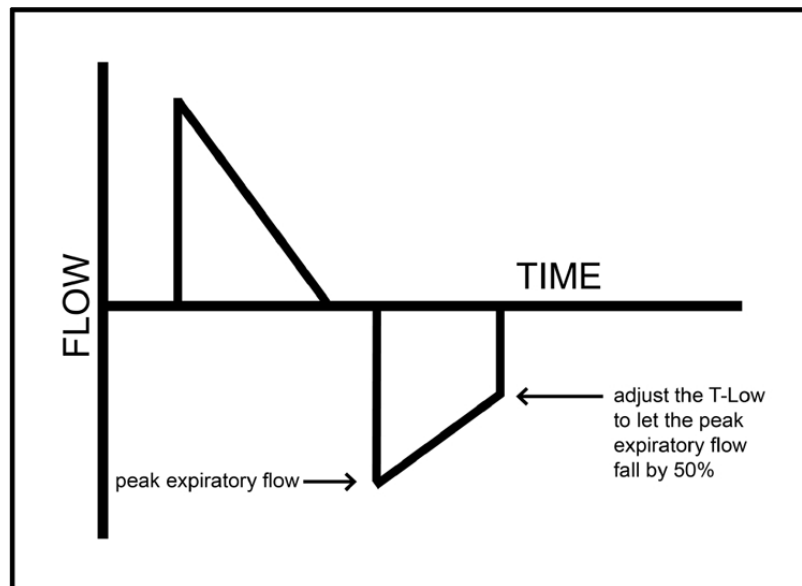

If oxygenation is the biggest problem, the  $T_{LOW}$  can be shortened to allow a drop in expiratory flow of 25%. This will result in less  $CO_2$  being ventilated but will also keep some additional alveoli open and improve oxygenation.

If ventilation is the more concerning issue, the  $T_{LOW}$  can be lengthened to allow a drop in expiratory flow of 75%. This will allow more  $CO_2$  to be ventilated but may result in more alveolar derecruitment, which could affect oxygenation.

## Weaning APRV

Weaning on APRV is easy. Keep in mind that this is nothing more than glorified CPAP. The patient can breathe on his own at the  $P_{HIGH}$  , and even if the tidal volumes are small, it's contributing to ventilation and to VQ matching. As the patient's compliance and gas exchange improve, he'll need

less of a  $P_{\text{HIGH}}$  and fewer releases a minute. This is what's called the "drop and spread" method of weaning—the  $P_{\text{HIGH}}$  is lowered in 1-2 cm increments, and the  $T_{\text{HIGH}}$  is gradually extended.

Once the  $T_{\text{HIGH}}$  is 8-10 seconds and the  $P_{\text{HIGH}}$  is less than 15, the patient can be switched to pressure support ventilation. Adding a small amount of PS (510 cm) makes up for taking away the intermittent releases. A typical switch would be if a patient were on APRV with a  $P_{\text{HIGH}}$  of 15 and a  $T_{\text{HIGH}}$  of 10 sec, and you changed the vent to pressure support ventilation with a CPAP of 12 (just under the  $P_{\text{HIGH}}$ ) and a PS of 8 (to boost his spontaneous breathing). Once he's on PSV, you can lower the CPAP as the oxygenation improves and adjust the PS to maintain comfortable spontaneous breathing.

As an aside, I don't recommend using PS at a  $P_{\text{HIGH}}$  more than 20, even though it's an option on some vents—it can increase the transpulmonary pressure during spontaneous breathing and lead to lung injury. [17](#)

# Chapter 15

## Liberation from Mechanical Ventilation

Liberation has replaced weaning as the preferred term for getting patients off the ventilator. This is because, for the most part, prolonged weaning is unnecessary. Weaning refers to a gradual reduction in ventilator support, either by reducing the rate in SIMV or by reducing the pressure support in PSV. Liberation, on the other hand, implies that the patient is assessed daily for his readiness for extubation and then extubated when he meets the proper criteria.

In order to extubate a patient safely, there are a few conditions that have to be satisfied. First, the reason for extubation needs to have resolved or been corrected. If a patient is intubated for altered mental status, he should be awake and able to follow directions. If he was intubated for pulmonary edema or shock, he should have clear lungs and be off vasopressors. And so forth.

Second, the patient should be able to maintain adequate gas exchange without positive pressure ventilation. The criteria most commonly used are an  $\text{FiO}_2 \leq 50\%$  and a  $\text{PEEP} \leq 8 \text{ cm H}_2\text{O}$ . Dynamic hyperinflation should not be present, and he should be able to maintain normocapnia without a very high minute ventilation (e.g. less than 10 liters per minute).

Third, he should have adequate cardiovascular reserve to tolerate unassisted breathing. Myocardial ischemia and reduced left ventricular function impair a patient's ability to breathe without assistance. Cardiogenic pulmonary edema benefits from the reduction in preload and afterload brought on by positive pressure breathing, and extubation can aggravate this. <sup>18</sup> A spontaneous breathing trial using a T-piece instead of CPAP or PSV may be helpful to determine if a patient with left ventricular dysfunction is ready for extubation.



Mental status is often a consideration when considering readiness for extubation. Patients who are stuporous or comatose have difficulty maintaining adequate airway tone and may have diminished protective reflexes, so aspiration and pneumonia are potential risks. In addition, patients with brain illness or injury can have disorders of central respiratory drive. Nevertheless, one study demonstrated that brain-injured patients who had no other reason to stay intubated other than mental status—that is, they didn't have high oxygen requirements, weren't being suctioned frequently, and didn't have periods of apnea—actually did better with early extubation. [19](#)

## Weaning Parameters

Several clinical indices are commonly used to assess readiness for extubation. These can be obtained at the bedside, without much need for specialized equipment.

**MIP:** maximal inspiratory pressure; also known as the negative inspiratory force (NIF). Healthy young men can generate a MIP of -120 cm H<sub>2</sub> O; women can generate a MIP of -90. For intubated patients, a MIP of less than -30 is usually considered adequate.

**FVC:** forced vital capacity. Normal subjects have an FVC of 70-80 mL/kg. In intubated patients, an FVC of 10-15 mL/kg is considered sufficient for unassisted breathing.

**Minute Ventilation:** a minute ventilation of more than 10 liters per minute to keep a normal PaCO<sub>2</sub> is generally too much work for a patient to perform without assistance from the ventilator.

Weaning parameters have several drawbacks, however. The MIP and FVC depend on adequate patient cooperation and effort, and they are static measurements at one point in time. The minute ventilation is a dynamic measurement over a period of time, but it may be affected by patient discomfort or agitation. None of these parameters have sufficient positive- or negative-predictive value by themselves, although they can be useful adjuncts to clinical decision-making. For the most part, weaning parameters have been replaced by the concept of the *spontaneous breathing trial*.

## Spontaneous Breathing Trial

A spontaneous breathing trial (SBT) is performed by observing a patient's respiratory efforts over a period of time, usually 30-120 minutes, with low or no ventilator support. One of the first major trials to show the utility of the SBT required putting the patient on a T-piece—oxygen tubing attached to the end of the endotracheal tube, which looks like the letter T.<sup>8</sup> The T-piece trial has the advantage of testing the patient's breathing without any ventilator support. It can be labor-intensive, though, and it's difficult to measure the tidal volume without a special device attached to the tube.

Other trials have shown that either CPAP alone,<sup>20</sup> or CPAP with the addition of low-level pressure support (5-8 cm H<sub>2</sub>O)<sup>21, 22</sup> are as effective as a T-piece SBT. Using CPAP or PSV has the advantage of letting you see the rate and tidal volume and not requiring disconnection from the ventilator.

At the conclusion of the SBT, assess the patient's readiness for extubation. Much of this is by a simple clinical examination—the person who is tachypneic, tachycardic, and diaphoretic is not ready; the person who is breathing slowly and deeply and seems comfortable probably is. In order to assist you, there's an index called the *Rapid Shallow Breathing Index*, or RSBI. This is the ratio between the patient's respiratory rate and the tidal volume (in liters). It's easier to breathe fast than deep, so a patient without a lot of respiratory muscle strength will take fast, shallow breaths. Slow, deep breaths are better. As an example, a patient with a respiratory rate of 10 and a tidal volume of 500 mL has an RSBI of 20 (10/0.5). Another patient with a respiratory rate of 50 and a tidal volume of 100 mL has an RSBI of 500 (50/0.1). Both have the same minute ventilation (10 L/min), but the latter patient is clearly not ready for extubation.

An RSBI of < 105 is predictive of successful extubation.<sup>23</sup> Since I do SBTs on the vent with PSV, I use a slightly stricter threshold of 80 to account for the assistance provided. You have to use some common sense and clinical judgment as well—someone with an RSBI of 75 who has a paradoxical breathing pattern and is gasping will probably not do too well off the vent. Another person with an RSBI of 110 who

otherwise looks calm and seems comfortable may in fact do well, and it could be worth giving her a chance.

An SBT should be done on every patient who meets the criteria. In order to be effective, the SBT assessment should be an automatic thing for all ventilated patients unless there's a specific reason not to (like an open chest, or high intracranial pressure, or a difficult airway). Ideally, the respiratory therapist will conduct the SBT at the same time that the nurse does the daily sedation vacation—this will improve your odds at getting patients extubated quickly. Remember that the ventilator is not therapeutic, and that the patient will come off the vent when he's ready. The purpose of the SBT is to recognize when he's ready and to not make him spend any more time on the vent than is necessary.

Daily SBTs have two advantages—first, they are simple to do. A daily assessment and spontaneous breathing trial takes up a short amount of time and gives you a reliable way to know who can be extubated and who cannot. Second, they are the most effective way of liberating patients from mechanical ventilation. Daily SBTs have proven superior to SIMV and PSV “weaning” in terms of time on the ventilator and length of stay in the ICU.<sup>18</sup>

There are two types of days for patients with respiratory failure—vent days and get-off-the-vent days. A daily spontaneous breathing trial lets you know which kind of a day it is. If the patient passes, extubate! If not, put him back on assist-control ventilation. There's no benefit from “working him out” or by finding the level of support just above that where he fatigues. Let him rest and try again tomorrow. This method is simple. It's easy to make a part of your daily practice in the ICU. And, it works.

### **Daily SBT Protocol**

#### **Assessment Criteria**

$FiO_2 \leq 50\%$

$PEEP \leq 8$

Able to follow directions

Not requiring frequent suctioning

Hemodynamically stable

Not a known difficult airway

Not on unconventional ventilation (APRV, HFOV)

No physician order for “No Daily SBT”

**If all of the assessment criteria are met, begin the Spontaneous Breathing Trial**

1. CPAP 5 cm, PS 7 cm for 30-60 minutes
2. At the end of the SBT, calculate the RSBI
3. If the RSBI is  $< 80$ , extubate the patient
4. If the RSBI is  $> 80$ , back to assist-control
5. If there is concern over the patient’s readiness for extubation, call the physician

**Abort the SBT for any of the following**

Desaturation below 88%

Increase in heart rate by 20 beats/min

Significant change in blood pressure

Diaphoresis

Accessory muscle use or paradoxical breathing pattern

# Chapter 16

## Prolonged Respiratory Failure

About 20% of ventilated patients will not be able to liberate quickly once their illness or injury resolves. This may be due to preexisting illnesses, poor cardiac function, chronic lung disease, malnutrition, deconditioning, or critical illness polyneuromyopathy. A good definition of prolonged respiratory failure, or difficult weaning, is when the patient is still intubated after at least three spontaneous breathing trials and more than seven days after resolution of the acute illness or injury.<sup>18</sup>

### Timing of tracheostomy

Timing of tracheostomy placement is controversial and varies widely between institutions and practitioners. While many critical care physicians would agree a tracheostomy should be performed after two weeks of respiratory failure, there are a substantial number who believe that this is too long to wait. The literature is divided on the topic—some studies have shown a benefit,<sup>24</sup> while a recent multicenter randomized trial showed no advantage to early tracheostomy.<sup>25</sup> In this trial, a significant number of patients randomized to tracheostomy at 14 days were extubated prior to the operation, suggesting that waiting is not necessarily a bad thing.

Benefits of earlier tracheostomy include patient comfort, increased mobility, less need for sedation, and a shorter time in the ICU. Drawbacks of tracheostomy include the need for an invasive procedure, the risk of tracheal stenosis, and the psychological burden it places on the patient (since many people associate a tracheostomy with chronic illnesses like cancer). There is a psychological shift among caregivers as well, in my experience—for some patients, once a tracheostomy is placed that person becomes a “trach patient.”

Physicians and nurses seem to be more likely to send a “trach patient” to a nursing home, and there can be a reluctance to decannulate (i.e. remove) the tracheostomy tube, even after the patient is liberated from the ventilator.

Like everything else, this decision needs to be individualized for the patient. If prolonged ventilation is anticipated due to neurologic illness or injury or because of airway obstruction, then tracheostomy should occur rather quickly. On the other hand, if the disease process is one where you expect recovery within one to two weeks (chest or abdominal trauma, pneumonia, status asthmaticus, CHF exacerbation), then I would wait.

### **Removing the Tracheostomy**

Once the patient is free of the vent, it’s time to begin thinking about decannulation. This, obviously, depends on many factors and there is no specific rule regarding when a tracheostomy tube can be removed. Some general requirements for decannulation are:

1. The patient should be able to get out of bed and get around (even with a wheelchair).
2. He should be able to speak and breathe comfortably with the tracheostomy tube occluded (e.g. with a Passy-Muir<sup>®</sup> Speaking Valve).
3. There should be no need for frequent suctioning or other pulmonary toilet measures.
4. There should be no anticipated need for positive pressure ventilation.

### **Contributors to Prolonged Respiratory Failure**

Many of the reasons why patients are ventilated are self-evident and should be treated. The following list mentions some that may not be as obvious. Dynamic hyperinflation, delirium, diaphragmatic paralysis, hypothyroidism and neuromuscular disease are all good examples of relatively common occult conditions leading to prolonged respiratory failure.

**Pulmonary:** dynamic hyperinflation, diaphragmatic paralysis, pulmonary fibrosis

**Cardiac:** impaired left ventricular systolic function, pulmonary hypertension, pericardial effusion, constrictive pericarditis

**Neurologic:** brainstem lesions, cervical spine injury or disease, neuromuscular disease

**Endocrine:** hypothyroidism, hypoadrenalism, low testosterone (in men)

**Malnutrition**

**Critical Illness Neuromyopathy**

**Deconditioning**

**Delirium**

## Nutritional Support

Adequate caloric and protein intake via the enteral route is a tenet of critical care medicine. For most patients in the ICU, nutritional needs can be estimated—25-30 kcal/kg from carbohydrates and fat, with 1-1.5 g/kg protein. For people with prolonged respiratory failure, I do a more detailed evaluation of their nutritional regimen every one to two weeks.

A balanced diet yields a respiratory quotient (RQ) of 0.8. The RQ represents the body's CO<sub>2</sub> production divided by its O<sub>2</sub> consumption. Different food sources have a different RQ—a diet consisting solely of fat would have an RQ of 0.7, while a carbohydrate-only diet has an RQ of 1.0. If the RQ is too high (0.85 or higher), it can lead to excessive work of breathing; after all, the lungs are the organs that have to clear all of the CO<sub>2</sub> produced by metabolism. A *metabolic cart study* can be used to determine the RQ. If it exceeds 0.85, I switch to a lower-carbohydrate tube feeding formula.

The metabolic cart study can also calculate the resting energy expenditure (REE) in kcal/day. There are many formulas for predicting how many calories over the REE a patient needs. I try to keep it simple and provide about 500 kcal above the REE, and I try to provide all of the patient's caloric needs with carbohydrates and fat (in a 60/40 ratio, to keep the RQ down). That way protein can be used to build muscle instead of being burned for energy.

Most of the nitrogen byproducts of protein metabolism are excreted in the urine. About 2 g N are lost in the stool, and another 2 g are lost through the skin. A 24-hour urine urea nitrogen (UUN) collection tells you how much is lost in the urine. Adding these up, we know the patient's daily nitrogen excretion. Since protein is 16% elemental nitrogen, multiplying the total daily nitrogen excretion by 6.25 gives the amount of protein, in grams, necessary to break even. In order to provide enough protein for skeletal muscle anabolism, I try to give about 10-20 grams of protein above this. For example, if a patient has a 24-hour UUN of 10 g N, his daily excretion is 14 g (10 from the urine, 2 from the stool, 2 from the skin). Multiplying 14 by 6.25 gives us 87.5 g protein needed to break even. Therefore, I would make sure he's taking in about 100 grams of protein a day.

### **Critical Illness Neuromyopathy**

This condition is fairly common in the ICU. Drugs associated with critical illness neuromyopathy include aminoglycoside antibiotics, corticosteroids, and neuromuscular blocking agents. Prolonged neuromuscular blockade with concurrent high-dose steroid therapy is one of the leading causes of this condition. Clinically, it's manifested by weakness and diminished reflexes. Physical exam findings can range from mild weakness to tetraparesis. Facial innervation is usually spared. Electromyography is confirmatory, but the appropriate clinical history is usually sufficient to make the diagnosis. Critical illness neuromyopathy can hamper efforts to get the patient off the vent. Unfortunately, there is no treatment for this other than good physical therapy and time.

### **Delirium**

Delirium can fall into two types—hyperactive and hypoactive. Hyperactive delirium is the kind that gets the most attention and the most late-night phone calls. Hypoactive delirium is less obvious but is still a problem. Both types can lead to prolonged respiratory failure, usually because of concerns for the patient's ability to protect his airway.



Delirium can be due to the patient's primary illness, medications, or environmental factors in the ICU. Important reversible causes of delirium include sepsis, alcohol withdrawal, stroke, myocardial ischemia, pulmonary embolism, and pain. All of these should be sought out if indicated and treated. Some patients are very difficult, if not impossible, to ventilate without heavy sedation. Tracheostomy can be beneficial, since the tracheostomy tube is much more tolerable than the endotracheal tube and the amount of sedation can be reduced.

Medications are another important cause of delirium. Prolonged benzodiazepine use, either by continuous infusion or intermittent dosing, can cause paradoxical agitation and confusion. Benzodiazepine infusions may make a patient look asleep, but there's very little REM sleep actually occurring. H<sub>2</sub>-receptor blockers and fluoroquinolones have also been implicated, especially in the elderly. Dexmedetomidine has been studied as a sedative for mechanically ventilated patients and seems to be associated with less delirium when compared with benzodiazepines.

Environmental factors can lead to the so-called "ICU psychosis," which I believe is a fancy term for sleep deprivation. It's very difficult to get a good night's sleep in the intensive care unit, and this is made worse by blood draws, fluorescent lights, alarms, and all of the other sights and sounds of a modern ICU. Every attempt should be made to permit patients to sleep at night. Minimizing nocturnal blood draws, unless they are truly necessary, is a good start. Turning out the lights and reducing ambient noise can also help.

## **Mobility**

It seems like common sense that ICU patients who are comatose, are in shock, or who have severe respiratory failure should remain on bedrest. What's not acceptable, however, is for a person to spend day after day flat on his back even after he's started to recover from his illness. Lying in bed all day is not healthy. Moreover, prolonged bedrest is associated with decubiti, deep venous thrombosis, atelectasis, pneumonia, muscle wasting, and other bad things.

There are no reasons why the majority of intubated patients should not get out of bed. It will take some assistance from the ICU staff, but it is definitely possible. The benefits are both physical and psychological. Sitting upright, or standing with assistance at the bedside, strengthens core muscles and helps prevent the muscle wasting often seen in critically ill patients. Atelectasis is reduced with positional changes and pulmonary gas exchange improves. Walking is also a possibility—you can either bag the patient through the endotracheal tube or push the ventilator behind him, since most vents have a battery and portable O<sub>2</sub> supply.

From a psychological standpoint, patients seem to need less sedation if they are able to move about and change position. Lying in bed all day may sound good to you, but that's if you can roll over, adjust your pillow, and sit up if you want to. When intubated patients try that, we tie them down with restraints and sedate them! It's also empowering—even a small amount of daily exercise can give people a sense of recovery.

I recommend that every patient in the ICU be evaluated by Physical Therapy. It's also important for the rest of the ICU staff to know that early mobility and walking are an important part of critical care and to make it part of the unit's daily routine. The only reasons why an intubated patient should not get out of bed are:

1. FiO<sub>2</sub> ≥ 60% or PEEP ≥ 10
2. Anatomic reason (fractured leg, open abdomen, open sternum, etc.)
3. Coma
4. Shock (on vasopressors)

That's it. Most ICU patients don't fall into these categories; therefore, most ICU patients should be moving!

## **Ventilator Weaning in Prolonged Respiratory Failure**

Most patients who are intubated don't need weaning—they need a daily assessment and spontaneous breathing trial.

For those who have failed this, however, some gradual reduction in ventilator support may be helpful. Unfortunately, there are no clinical trials showing benefit of one approach over another. Some centers use SIMV weaning, where the vent rate is reduced daily, and then the pressure support. Other centers use PSV during the day, adjusted to maintain comfortable breathing, with assist-control at night for respiratory muscle rest. Still others use periods of unassisted breathing (T-piece or trach mask) as tolerated, with assist-control ventilation in the event of fatigue.

Since the ventilator itself is not therapeutic, it really doesn't make sense that a particular mode of ventilation would prove to be superior. It does make sense that fatigue is harmful, so a protocolized approach with a gradual reduction in support should be better than going all-or-nothing. The most important factor is the standardization in a particular institution—the method of weaning is less important than having a method in the first place. If the vent weaning strategy varies wildly depending on which physician is rounding on a particular day, then it's going to be hard to have successful results.

In addition, attention to the non-respiratory things is important. Ensuring adequate nutrition, mobility, and preventing delirium is as fundamental as having a ventilator weaning strategy. Like everything else in critical care, the details matter.

Finally, be realistic. There will be good days, bad days, and setbacks. Don't get discouraged and don't let the patient get discouraged. It may be necessary to pause ventilator weaning for a few days, but it shouldn't lead to giving up in frustration. Stay positive!

### **SIMV with PS Ventilator Weaning Protocol <sup>\*</sup>**

- Assumes patient has a tracheostomy
- Tidal volume 8 mL/kg PBW when on SIMV
- FiO<sub>2</sub> 30-50%, PEEP 5-8

- If the patient can't complete the step, return to the vent (if on trach collar) or go back 1-3 steps as needed (if on the vent) and try again the next day

<u>Day</u>	<u>Trach Collar Time</u>	<u>Vent Settings</u>
1	-	Rate 10, PS 20
2	-	Rate 8, PS 20
3	-	Rate 6, PS 20
4	-	Rate 4, PS 20
5	-	Rate 4, PS 18
6	-	Rate 4, PS 16
7	-	Rate 4, PS 14
8	-	Rate 4, PS 12
9	-	Rate 4, PS 10
10	1 hour	Rate 4, PS 10
11	2 hours	Rate 4, PS 10
12	4 hours	Rate 4, PS 10
13	6 hours	Rate 4, PS 10
14	8 hours	Rate 4, PS 10
15	10 hours	Rate 4, PS 10
16	12 hours	Rate 4, PS 10
17	16 hours	Rate 4, PS 10
18	20 hours	Rate 4, PS 10
19	24 hours	-
20	24 hours	-
21	24 hours	-

### **PRVC with Automode $\ddagger$ Ventilator Weaning Protocol**

- Assumes patient has a tracheostomy
- Tidal Volume 8 mL/kg PBW
- Rate 10
- FiO<sub>2</sub> 30-50%, PEEP 5-8

Activate Automode (in PRVC on the Servo ventilator, this will be Volume Support)

In Volume Support, the ventilator will allow the patient to breathe spontaneously as in Pressure Support Ventilation but will adjust the inspiratory pressure as needed to reach the goal tidal volume. Think of it as an auto-adjusted pressure support.

As the patient's compliance and strength improve, it will take less pressure to get the goal tidal volume. The peak inspiratory pressure will drop accordingly.

If the patient's condition worsens, it will take more pressure to get to the goal tidal volume and the peak inspiratory pressure will increase accordingly.

Every day, put the patient on trach collar for as long as tolerated. Return to PRVC/Automode when he gets tired.

---

\* Modified from the TIPS Ventilator Weaning Protocol [ *Chest* 2001 Jan; 119(1): 236-42.]

† For use with the Maquet Servo ventilator. This could be adapted easily to whichever ventilator you're using—for example, instead of Automode, you could use Proportional Assist. Read the instruction manual that came with the ventilator.

# Appendix of Useful Knowledge

*(For board exams, ICU rounds, and to occasionally help an actual patient!)*

## **Alveolar Gas Equation**

$$P_A O_2 = [(P_B - P_{H_2O}) \times F_i O_2] - (P_a CO_2 / RQ)$$

$$\text{Simplified: } P_{A O_2} = 713(F_i O_2) - 1.2(P_a CO_2)$$

## **Oxygen Content Equation**

$$CaO_2 = 1.34(\text{Hgb})(SaO_2) + 0.003(PaO_2)$$

Normal  $CaO_2$  : 20 mL  $O_2$  /dL blood

## **Oxygen Delivery Equation**

$$DO_2 = CaO_2 \times C.O. \times 10$$

(C.O. = cardiac output in L/min)

Normal  $DO_2$  : 1000 mL  $O_2$  /min

## **Oxygen Consumption Equation**

$$VO_2 = (CaO_2 - CvO_2) \times C.O. \times 10$$

( $CvO_2$  is the content of mixed venous blood obtained from a PA catheter)

Normal  $VO_2$  : 250 mL  $O_2$  /min

## **Oxygen Extraction Ratio**

$$O_2 \text{ ER} = VO_2 / DO_2$$

$$\text{Simplified: } O_2 \text{ ER} = (SaO_2 - SvO_2) / (SaO_2)$$

Normal  $O_2$  ER is 25%

## **Pulmonary Shunt Equation**

$$(C_C O_2 - CaO_2) / (C_C O_2 - CvO_2)$$

$C_C O_2$  is the oxygen content of the pulmonary capillary blood. This can't be measured, so the saturation is assumed to be 100% and the  $P_A O_2$  is estimated by the alveolar gas equation. Normal pulmonary shunt: less than 3%

### **P/F Ratio**

$PaO_2 / FiO_2$  , with the  $FiO_2$  expressed as a decimal (e.g. 50% oxygen is expressed as 0.50).

A normal P/F ratio is  $> 500$ . A P/F ratio  $< 200$  usually indicates a shunt fraction in excess of 20%, which suggests that the patient still needs mechanical ventilation.

# References

---

- <sup>1</sup> Joseph E. Parrillo and R. Phillip Dellinger (eds). *Critical Care Medicine: Principles of Diagnosis and Management in the Adult*. Mosby, 2004: 705.
- <sup>2</sup> Treacher DF, Leach RM. Oxygen transport—1. Basic principles. *BMJ* 1998; 317:1302-1306.
- <sup>3</sup> “Principles of pulse oximetry.” *Anaesthesia UK*. 11 Sep 2004. Web address: <http://www.frca.co.uk/article.aspx?articleid=332>
- <sup>4</sup> The ARDS Network. Ventilation with lower tidal volumes as compared with traditional tidal volumes for acute lung injury and the acute respiratory distress syndrome. *N Engl J Med*. 2000; 324:1301-1308.
- <sup>5</sup> Gajic O, et al. Ventilator-associated lung injury in patients without acute lung injury at the onset of mechanical ventilation. *Crit Care Med*. 2004; 32:1817–1824.
- <sup>6</sup> Frank JA, Matthay MA. Science review: mechanisms of ventilator-induced injury. *Crit Care*. 2003; 7:233–241.
- <sup>7</sup> Amato MB, Meade MO, Slutsky AS, Brochard L, Costa EL, Schoenfeld DA, Stewart TE, Briel M, Talmor D, Mercat A, et al. Driving pressure and survival in the acute respiratory distress syndrome. *N Engl J Med*. 2015;372(8):747–55.
- <sup>8</sup> Esteban A, Frutos F, Tobin MJ, et al. A comparison of four methods of weaning patients from mechanical ventilation. *N Engl J Med*. 1995; 332:345–50.
- <sup>9</sup> Brower, RG, Lanken PN, MacIntyre N, et al. Higher versus lower positive end expiratory pressures in patients with the acute respiratory distress syndrome. *N Engl J Med*. 2004; 351:327-336.
- <sup>10</sup> Gattinoni L, Carlesso E, Brazzi L, et al. Friday night ventilation: a safety starting tool kit for mechanically ventilated patients. *Minerva Anestesiol* 2014; 80:1046–1057.
- <sup>11</sup> ART Investigators. Effect of Lung Recruitment and Titrated Positive End-Expiratory Pressure (PEEP) vs Low PEEP on Mortality in Patients With Acute Respiratory Distress Syndrome. *JAMA*. 2017;318(14):1335-1345.
- <sup>12</sup> Georgopoulos D, Giannouli E, Patakas D. Effects of extrinsic positive end-expiratory pressure on mechanically ventilated patients with chronic obstructive pulmonary disease and dynamic hyperinflation. *Intensive Care Med*. 1993; 19(4):197-203.
- <sup>13</sup> Chang KPW, Stewart TE, Mehta S. High frequency ventilation for adults with ARDS. *Chest*. 2007; 131:1907-1916.
- <sup>14</sup> Fessler HE, Derdak S, Ferguson ND, et al. A protocol for high frequency oscillation in adults: results from a round table discussion. *Crit Care Med*. 2007; 35:1649–1654.
- <sup>15</sup> Ferguson ND, Cook DJ, Guyatt GH, et al. High-frequency oscillation in early acute respiratory distress syndrome. *N Engl J Med* 2013; 368: 795-805.



- [16](#) Young D, Lamb SE, Shah S, et al. High-frequency oscillation for acute respiratory distress syndrome. *N Engl J Med* 2013; 368: 806-813.
- [17](#) Habashi NM. Other approaches to open lung ventilation: airway pressure release ventilation. *Crit Care Med*. 2005; 33:S228-S240.
- [18](#) Boles JM, Bion J, Connors A, et al. Weaning from mechanical ventilation. *Eur Respir J*. 2007; 29:1033-1056.
- [19](#) Coplin WM, Pierson DJ, Cooley KD, et al. Implications of extubation delay in brain-injured patients meeting standard weaning criteria. *Am J Respir Crit Care Med*. 2000; 161:1530– 1536.
- [20](#) Jones DP, Byrne P, Morgan C, et al. Positive end-expiratory pressure versus T-piece. Extubation after mechanical ventilation. *Chest*. 1991; 100:1655–1659.
- [21](#) Matic I, Majeric-Kogler V. Comparison of pressure support and T-tube weaning from mechanical ventilation: randomized prospective study. *Croat Med J*. 2004; 45:162–166.
- [22](#) Esteban A, Anzueto A, Frutos F, et al. Mechanical Ventilation International Study Group. Characteristics and outcomes in adult patients receiving mechanical ventilation: a 28-day international study. *JAMA*. 2002; 287:345–355.
- [23](#) Yang KL, Tobin MJ. A prospective study of indexes predicting the outcome of trials of weaning from mechanical ventilation. *N Engl J Med*. 1991; 324:1445–1450.
- [24](#) Rumbak MJ, Newton M, Truncale T, et al. A prospective, randomized, study comparing early percutaneous dilational tracheotomy to prolonged translaryngeal intubation (delayed tracheotomy) in critically ill medical patients. *Crit Care Med*. 2004; 32:1689–1694.
- [25](#) Terragni PP, Antonelli M, Fumagalli R, et al. Early vs. late tracheotomy for prevention of pneumonia in mechanically ventilated adult ICU patients. *JAMA*. 2010; 303:1483-1489.

## **Acknowledgements**

I was moved to write this book by the fellows, residents, nurses, and medical students that I teach in the intensive care unit—my goal was to provide a guide to help them understand a subject that I find fascinating.

My wife, Lorien, has been by my side throughout the writing of three books (and counting). She is my editor, my graphic designer, my social media engineer, and the love of my life.

Keeping up with the latest developments in clinical medicine is always a challenge, and I've found that the best way for me to stay sharp is to surround myself with great people who share a passion for the care of the critically ill and injured. My good friend and colleague, David Dunlap, RRT, is always ready to try something new if it will benefit a patient. We have worked together for years and I know I am a better physician because of it.

In the first edition of this book, I said that all that I have done is possible because of the love and teaching I have received from my parents, Ben and Patricia Owens. This remains true as always.

## **About the Author**

William Owens, MD, is the Director of the Medical Intensive Care Unit at Palmetto Health Richland, a tertiary referral center in Columbia, SC. He is also the Division Chief for Pulmonary, Critical Care, and Sleep Medicine in the Palmetto Health-USC Medical Group and an Associate Professor of Clinical Medicine with the University of South Carolina. He has also served on the faculty at the University of Pittsburgh School of Medicine.

Dr. Owens is a graduate of The Citadel and the University of South Carolina School of Medicine. He trained in Emergency Medicine at the Earl K. Long Medical Center in Baton Rouge, LA. He did his fellowship training in Critical Care Medicine at the University of South Florida in Tampa, FL. He is board-certified in Emergency Medicine, Critical Care Medicine, and Neurocritical Care Medicine. He has spoken at regional and national conferences and has published articles in the peer-reviewed medical literature.

Throughout his career, Dr. Owens has been an active clinician and educator. He enjoys training physicians, nurses, and respiratory therapists in the care of the most seriously ill and injured patients and is a firm believer in a holistic approach to critical care medicine. He believes in the rational application of physiology and in always questioning our assumptions.

Dr. Owens lives in Columbia, SC, with his wife and three free-range children. He also lives with a St. Bernard and a beehive with about 60,000 bees. He enjoys mountain biking, whitewater kayaking, playing lacrosse, and going on family adventures.